

8 7 6 5 4 3 2 1

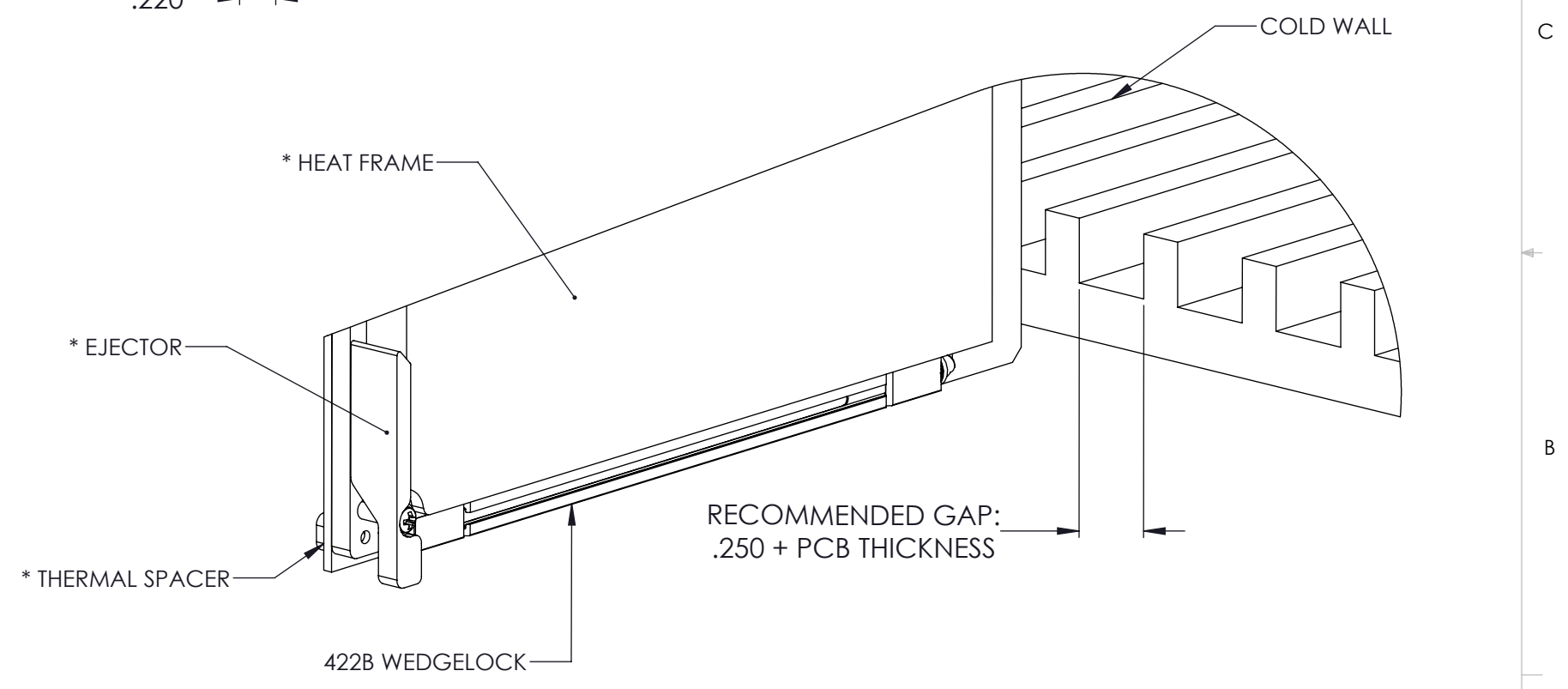
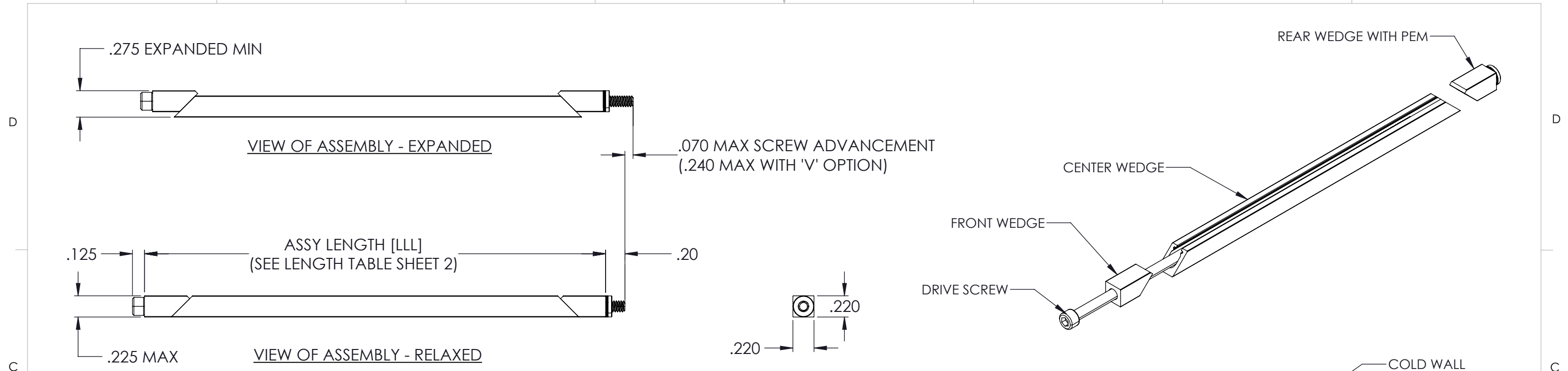

- FEATURES**
- DESIGNED FOR HEAVY SHOCK AND VIBRATION.
 - UNIFORM CLAMPING FORCE AND HIGH THERMAL TRANSFER.
 - NARROW WIDTH FOR MAXIMUM PCB COMPONENT AREA.
 - LIGHT WEIGHT = ASSEMBLY LENGTH X .080 OZ [2.27 G] OR [.89 G/CM]
 - SPECIAL LENGTHS, FINISH, AND OTHER DESIGN OPTIONS AVAILABLE UPON REQUEST.

MATERIAL
 WEDGES: ALUMINUM 6061-T6.
 ALL OTHER HARDWARE: STAINLESS STEEL, PASSIVATED.

PARTS ARE SHIPPED AS COMPLETE ASSEMBLY EXCEPT FOR RIVET MOUNT OPTION (SEE SHEET 2)
 RECOMMENDED DRIVE SCREW TORQUE IS 6 IN-LBS (68 N-CM)

* CONTACT WAKEFIELD FOR COMPLETE HEATFRAME ASSEMBLY OR OTHER COMPONENT ITEMS

THIS DOCUMENT, IN ITS ENTIRETY, CONTAINS INFORMATION WHICH IS CONFIDENTIAL AND PROPRIETARY TO WAKEFIELD THERMAL. DOCUMENTS MARKED WITH PROPRIETARY ARE NOT TO BE USED, DUPLICATED OR DISCLOSED WITHOUT PRIOR WRITTEN PERMISSION OF AN OFFICER OR DULY AUTHORIZED REPRESENTATIVE OF WAKEFIELD THERMAL OR AS MAY BE PROVIDED IN A WRITTEN NON-DISCLOSURE AGREEMENT BETWEEN THE PARTIES.

CAD GENERATED DRAWING				 2910 INDUSTRIAL DRIVE, RALEIGH, NC 27609	
TOLERANCES UNLESS OTHERWISE SPECIFIED:		NAME	DATE	TITLE: 422B WEDGELOCK DATASHEET .220 X .220	
X.XX ± 0.010"		DRAWN	10/1/2021		
X.XXX ± 0.005"		CHECKED			
ANGULAR ± 1°		ENG APPR.	10/1/2021		
MACHINED SURFACES ⁶³ ✓		MFG APPR.		REV 21A	
INTERPRET GEOMETRIC TOLERANCES PER: ASME Y14.5M-1994		Q.A.			
MATERIAL:	SEE PART DETAIL	SIZE	DWG NO.	422B-DS	
FINISH:	SEE FINISH TABLE	B			
DO NOT SCALE DRAWING		CAGE CODE:	3E7U8	SCALE 1:1	SHEET 1 OF 2
MODEL_INFO:		422B-480SSX-00			

8 7 6 5 4 3 2 1

[LLL] LENGTH TABLE		
ASSY LENGTH [LLL]	[H] MTG X	[C] OPITON X/2
280	0.900	0.450
330	1.400	0.700
380	1.900	0.950
430	2.400	1.200
480	2.900	1.450
530	3.400	1.700
580	3.900	1.950
OTHER LENGTHS AVAILABLE UPON REQUEST		

[H] MOUNTING TABLE	
DASH NO	DESCRIPTION
A	NO MOUNTING HOLES
\triangle R	ϕ 0.068/0.073 THRU \square ϕ .156 X ∇ .16 \checkmark ϕ 0.140 X 100°
T	#0-80 UNF-2B THREADS
S	#2-56 UNC-2B THREADS
U	M2 X 0.4 - 6H THREADS
M	M2.5 X 0.45 - 6H THREADS
THREAD DEPTH ~0.50" THRU	

[F] FINISH TABLE	
DASH NO	DESCRIPTION
A	NO FINISH
G	CHROMATE PER MIL-DTL-5541, CLASS 1A, TYPE I (GOLD)
T	TRIVALENT CHROMATE PER MIL-DTL-5541, CLASS 1A, TYPE II (CLEAR), RoHS COMPLIANT
B	BLACK ANODIZE PER MIL-A-8625, TYPE II, CLASS 2
H	HARD BLACK ANODIZE PER MIL-A-8625, TYPE III, CLASS 2
D	HARD BLACK ANODIZE PER MIL-A-8625, TYPE III, CLASS 2 WITH DRY FILM LUBE PER MIL-L-46010
E	ELECTROLESS NICKEL PER MIL-C-26074, CLASS 4, GRADE B, BRIGHT
*N	NADCAP COMPLIANT (EX: 'BN' - BLACK ANODIZE, NADCAP)

EXAMPLE
 422B-480UMG-CP
 422B WEDGELOCK ASSEMBLY
 4.80" LENGTH, M2 MTG, M2.5 SOCKET HEAD, GOLD CHROMATE
 CENTER MTG HOLE, LOCK PATCH

PART NUMBER CODE
 422B-[LLL][H][D][F]-[C][W][N][P][V]

PART DEFINITION (REQUIRED)

PART NUMBER OPTIONS (NOT REQUIRED)

SERIES PN

ASSY LENGTH (SEE LENGTH TABLE)

MOUNTING HOLE (SEE MOUNTING TABLE)

DRIVE SCREW
 'M' FOR M2.5 HEX
 'S' FOR 3/32 HEX

FINISH (SEE FINISH TABLE)

ADD 'C' FOR OPTIONAL CENTER MOUNTING HOLE

ADD 'W' FOR OPTIONAL LOCK AND FLAT WASHER

OPTIONAL LOCK NUT
 ADD 'A' FOR MS21043-04 SILVER PLATED A286 SS
 ADD 'N' FOR MS21042-04 CADMIUM PLATED STEEL

ADD 'P' FOR OPTIONAL LOCK PATCH

ADD 'V' FOR OPTIONAL VISUAL INDICATOR

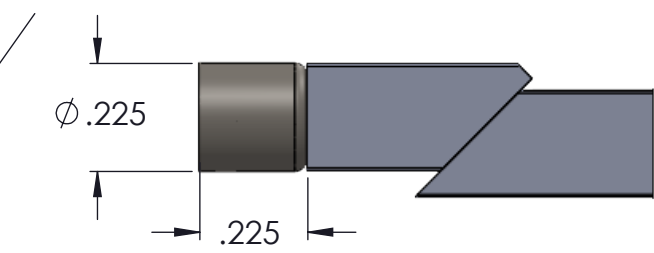
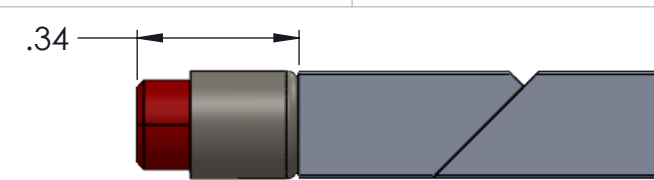

'V' OPTION
 VISUALLY CONFIRMS LOCKED IN PLACE WHEN RED SCREW HEAD IS CONCEALED

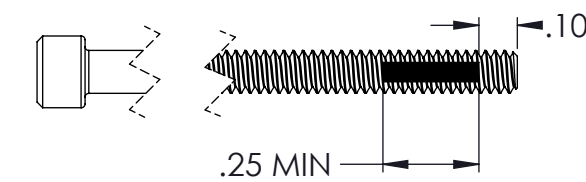

'P' OPTION
 NYLON PATCH PER MIL-F-18240 PROVIDES ADDITIONAL RESISTANCE TO SHOCK AND VIBRATION

'A' OR 'N' OPTION
 PREVENTS DISASSEMBLY OF REAR WEDGE FROM SCREW

'W' OPTION
 LOCK AND FLAT WASHER

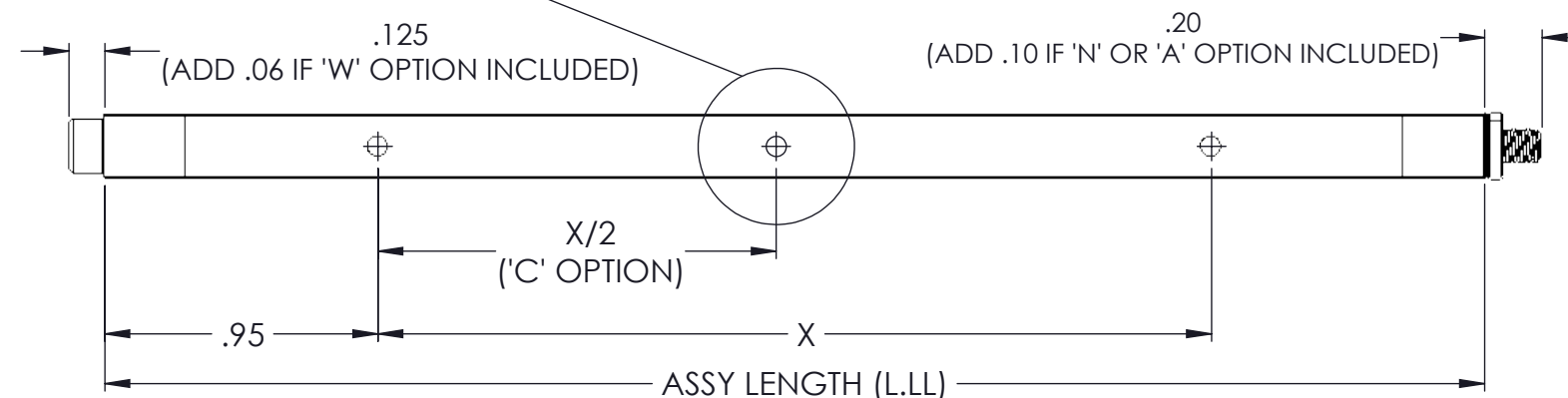
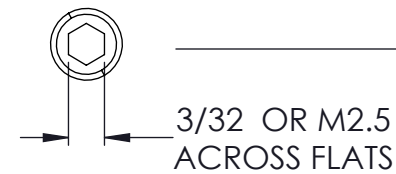

BOTTOM VIEW

NOTES:
 \triangle SHIP AS COMPLETE ASSEMBLY IN RELAXED STATE (IF RIVET MOUNTING OPTION IS SELECTED, SHIP UNASSEMBLED)

THIS DOCUMENT, IN ITS ENTIRETY, CONTAINS INFORMATION WHICH IS CONFIDENTIAL AND PROPRIETARY TO WAKEFIELD THERMAL. DOCUMENTS MARKED WITH PROPRIETARY ARE NOT TO BE USED, DUPLICATED OR DISCLOSED WITHOUT PRIOR WRITTEN PERMISSION OF AN OFFICER OR DULY AUTHORIZED REPRESENTATIVE OF WAKEFIELD THERMAL OR AS MAY BE PROVIDED IN A WRITTEN NON-DISCLOSURE AGREEMENT BETWEEN THE PARTIES.

SIZE	DWG NO.	REV
B	422B-DS	21A
CAGE CODE:	SCALE 1:1	SHEET 2 OF 2
3E7U8		

MODEL_INFO:
 422B-480SSX-00