

DC FANS

Wakefield Thermal produces a line of DC axial fans used on fan heat sinks which are commonly used on heatsinks to support BGAs, VGAs and CPU coolers or as chassis fans. The fans range in size from 30x10mm to 120x38mm with the most common sizes in between. The fans are available in 12 volt as the most common, but 5, 24 and 48 available. The standard configurations include 2 wire, 3 wire (tach) or 4 wire (PWM) and can be customized to support any range of connectors. The fans can also support an IP rating of IP55 for all models and voltages, if required.



General Fan Specifications

Operation Temperature:

-10C to +70C (+14F to +158F)

Storage Temperature:

-40C to +70C (-40F to +158F)

Bearing System Life:

2 Ball Bearing: L10 - 70k hrs @ 40C

Materials:

Black PBT(UL94V0), Glass Filled

Lead Wires:

Rating: UL1007 or UL1571, 80C

AWG: 24 or 26 or 28

Wire Length: 300mm +/- 10mm

3 Wire Standard: Red(+), Black(-), Yellow(Tach/FG)

4th wire Optional: Blue (PWM)

Insulation Resistance:

Standard: 10M Ω at 500VDC Minimum(frame to leads)

Dielectric Strength

Standard: 500VAC(50/60Hz) for 60 seconds with 1mA trip current allowable between frame and leads

Noise Data:

All noise readings are taken in dBA at 1 meter from air intake side, fan suspended in a semi-anechoic chamber (<16 dBA max)

Protection:

Locked Rotor (Meets UL standard 72 hr test)

Reversed Polarity

Shock and Vibration:

Shock: Meets 100G at 2ms, half sine, X, Y, and Z axis

Vibration: Meets the amplitude of vibration :0.38mm

Frequency: 5-55 Hz

Duration: 60min / axis

Direction: X.Y.Z axis



Part Numbering Guide



Example: DC402012H2B-2Tx [-IP55]

Series	Frame Size(mm)	Thickness (mm)	Voltage	Speed	Bearing	# of Wires	Termination	IP Rating
DC	40	20	12	H	2B	2	Tx	

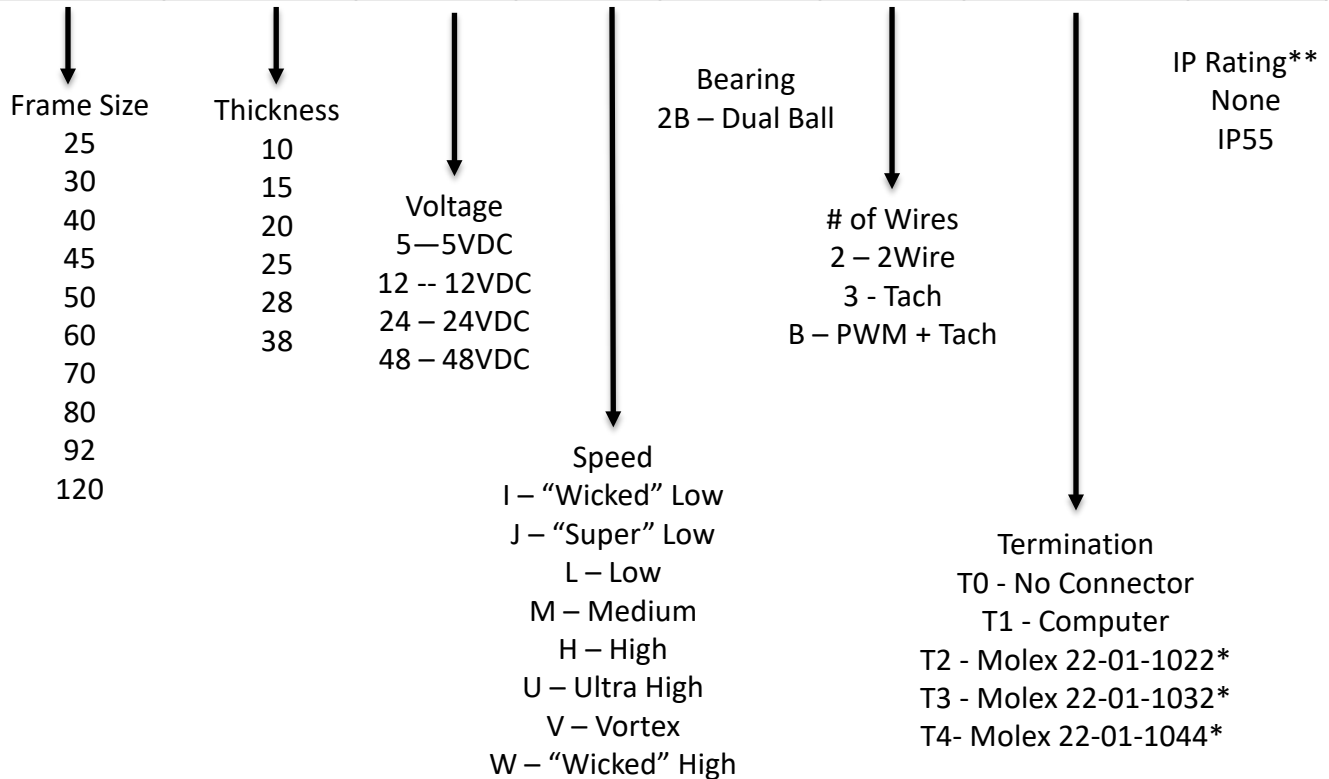

* Or equivalent

** No value means no rating

Bearing Information

Dual Ball Bearing

The two ball bearing system is the industry standard for long life with a L10 of 70,000 hours. Other bearing choices, like sleeve or single ball are susceptible to impact damage which is why they can not support the high life requirement of most applications. One advantage of two ball bearing systems is that due to the small point load of the balls, they require less power to start rotation as they have less stiction (starting friction) than other bearing system which means the minimum starting power can be achieved with a lower current.

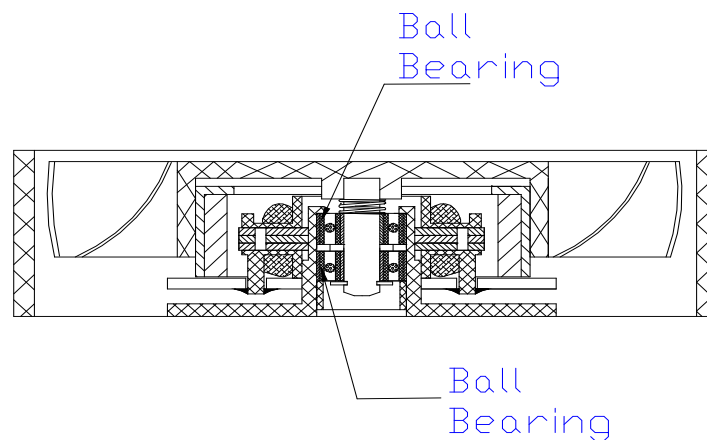

Bearing Lubrication, Wear and Failure

Bearing failure is the most common reason for a fan failure which is why bearing selection is so important. The bearing failure can be caused by multiple factors including lack of lubrication, excessive temperature or direct damage (excessive shock/vibration). A two ball bearing fan is better sealed to prevent the leak of the lubrication fluid than some of the other bearing systems. All fans typically will get noisier and rotate slower as the bearing systems wear and this can be a good indicator of pending bearing failure.

Optional Configuration

- 3 – Tach

FREQUENCY GENERATOR (FG) SIGNAL

SCHEMATIC

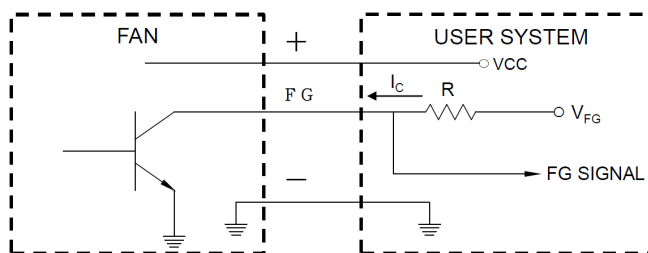

CAUTION:

THE LEAD WIRE OF FG SIGNAL CAN NOT TOUCH THE LEAD WIRE OF POSITIVE OR NEGATIVE

SIGNAL SPECIFICATION:

OUTPUT TYPE: OPEN COLLECT

V_{FG} MAXIMUM VOLTAGE=13.2V

I_C MAXIMUM CURRENT= 5mA

LOW LEVEL VOLTAGE= 0.5V MAX

$R \geq V_{FG} / I_C$

FREQUENCY GENERATOR WAVEFORM

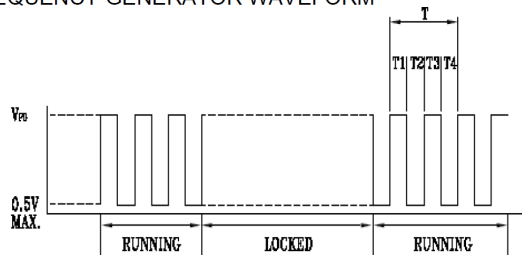

$$T = T1 + T2 + T3 + T4 = 60/N(\text{Sec})$$

N: SPEED (RPM)

- B – PWM + Tach

PWM CONTROL

SIGNAL DESCRIPTION

1. CONTROL SIGNAL: PWM CONTROL

2. SIGNAL TYPE:

INPUT HIGH LEVEL VOLTAGE: MIN > 2.6V, MAX < 5V

INPUT LOW LEVEL VOLTAGE: MAX < 0.5V

3. PWM FREQUENCY RANGE: VARIES BY MODEL, BUT 20K – 100KHZ TYPICAL

4. MAX SINK CURRENT: 8mA

FAN SPEED CONTROL

1. THE FAN SPEED SHOULD RUN AT FULL SPEED GIVEN PWM 100% DUTY CYCLE INPUT

2. THE FAN SPEED SHOULD RUN AT ZERO SPEED GIVEN BELOW PWM 0% DUTY CYCLE INPUT

3. THE FAN WILL GO TO FULL SPEED WHEN/IF THE CONTROL SIGNAL IS DISCONNECTED.

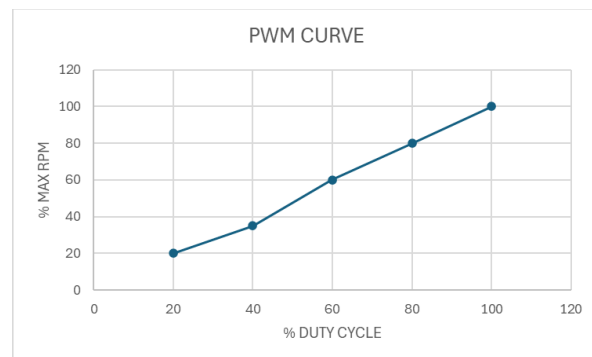

EXAMPLE DUTY CYCLE VS RPM CHART

Termination Information

- T0 – 5mm +/-2mm strip length, tinned
- T1 – Computer connector
 - Molex 22-01-1032 with AMP 60618-4)
 - Pin1 – Negative
 - Pin2 – Positive
 - Pin3 –Tachometer
 - AMP 60618-4
 - Pin1 – Positive
 - Pin2 – Negative
- T2 – Molex 22-01-1022*
 - Pin1 – Positive
 - Pin2 – Negative
- T3 – Molex 22-01-1032*
 - Pin1 – Positive
 - Pin2 – Negative
 - Pin3 – Tachometer
- T4 – Molex 22-01-1042*
 - Pin1 – Positive
 - Pin2 – Negative
 - Pin3 – Tachometer
 - Pin4 -- PWM

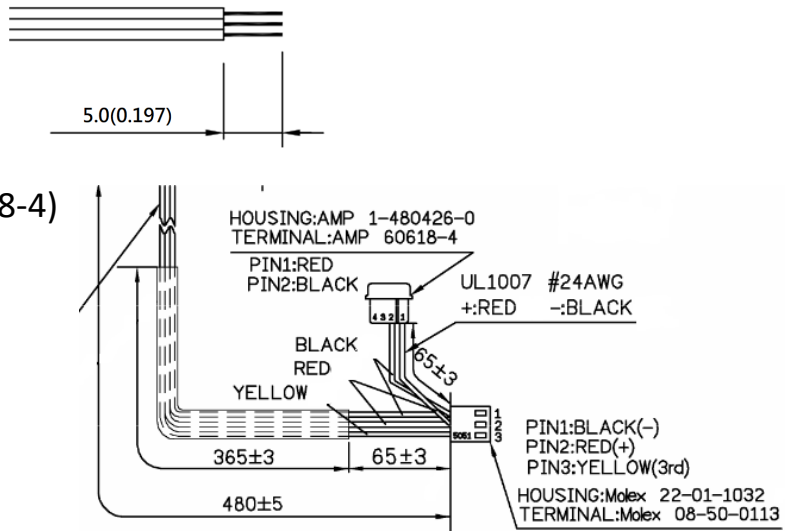

Typical Ordering Configurations

- 2T0 (2 wire, no connector)
- 2T2 (2 wire, 2 pin connector)
- 3T0 (3 wire, no connector)
- 3T1 (3 wire, computer connector)
- 3T3 (3 wire, 3 pin connector)
- BT0 (4 wire, no connector)
- BT4 (4 wire, 4 pin connector)

* Or equivalent

25x25x10mm



- MOTOR : DC single phase brushless motor
- FRAME : PBT (94V-0) ; IMPELLER : PBT(94V-0)
- OPERATING TEMP.: -10°C~70°C
- STORAGE TEMP.: -40°C~70°C
- WEIGHT : 8g
- Dual Ball Bearing
- Lead Length: 300mm +/- 10mm
- 2 Wire: Standard
- 3 Wire: Tach (FG) Optional
- 4 Wire: PWM Optional
- IP Rating: IP55 Optional

Description	Size (mm)	Thickness (mm)	Rated Voltage (VDC)	Rated Current (A)	Rated Power (W)	Rated Speed (RPM)	Speed Code	Max Airflow (CFM)	Max Pressure (InAq)	Noise Level (dB/A)	Tach	PWM
DC0251005H2B	25	10	05	0.16	0.8	13000	H	2.41	0.29	28	3	B
DC0251005M2B	25	10	05	0.11	0.55	10000	M	1.85	0.17	24	3	B
DC0251005L2B	25	10	05	0.07	0.35	7000	L	1.32	0.07	20	3	B
DC0251012H2B	25	10	12	0.08	0.96	13000	H	2.41	0.29	28	3	B
DC0251012M2B	25	10	12	0.06	0.72	10000	M	1.85	0.17	24	3	B
DC0251012L2B	25	10	12	0.05	0.6	7000	L	1.32	0.07	20	3	B

See page 6 for termination configurations and typical ordering configurations

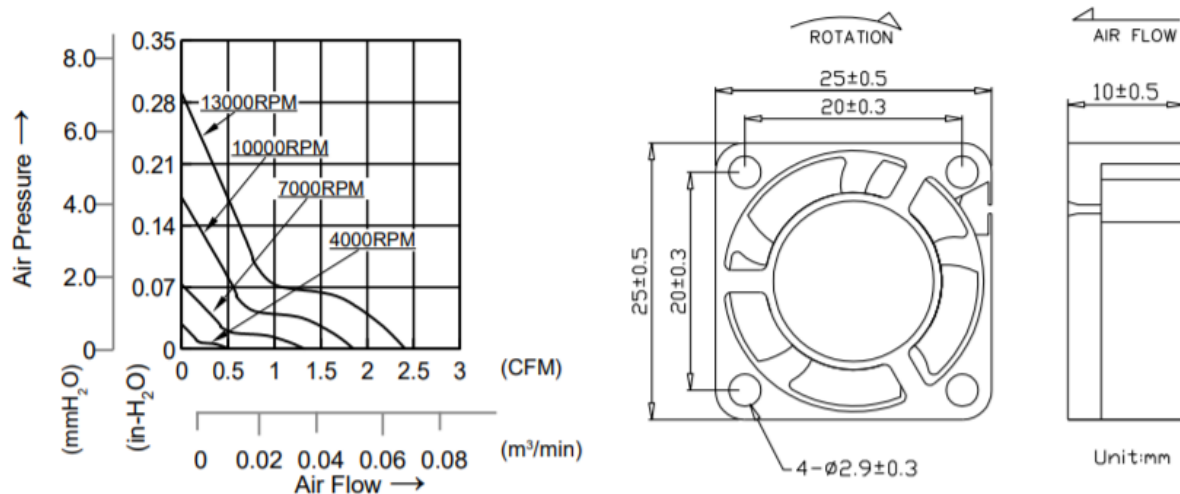

30x30x10mm



- MOTOR : DC single phase brushless motor
- FRAME : PBT (94V-0) ; IMPELLER : PBT(94V-0)
- OPERATING TEMP.: -10°C~70°C
- STORAGE TEMP.: -40°C~70°C
- WEIGHT : 10g
- Dual Ball Bearing
- Lead Length: 300mm +/- 10mm
- 2 Wire: Standard
- 3 Wire: Tach (FG) Optional
- 4 Wire: PWM Optional
- IP Rating: IP55 Optional

Description	Size (mm)	Thickness (mm)	Rated Voltage (VDC)	Rated Current (A)	Rated Power (W)	Rated Speed (RPM)	Speed Code	Max Airflow (CFM)	Max Pressure (InAq)	Noise Level (dB/A)	Tach	PWM
DC0301005U2B	30	10	05	0.32	1.60	11000	U	5.65	0.24	31	3	B
DC0301005H2B	30	10	05	0.23	1.15	9000	H	4.48	0.21	29	3	B
DC0301005M2B	30	10	05	0.13	0.65	7500	M	3.73	0.14	24	3	B
DC0301005L2B	30	10	05	0.10	0.50	6000	L	2.99	0.09	17	3	B
DC0301012U2B	30	10	12	0.17	2.04	11000	U	5.65	0.24	31	3	B
DC0301012H2B	30	10	12	0.07	0.84	9000	H	4.48	0.21	29	3	B
DC0301012M2B	30	10	12	0.05	0.60	7500	M	3.73	0.14	24	3	B
DC0301012L2B	30	10	12	0.03	0.36	6000	L	2.99	0.09	17	3	B

See page 6 for termination configurations and typical ordering configurations

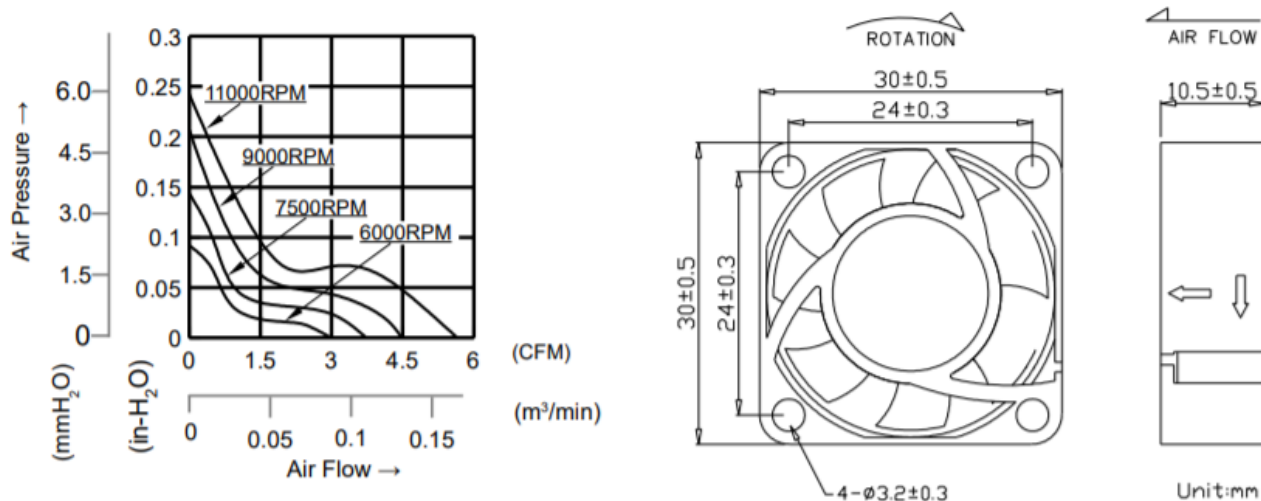

35x35x10mm



- MOTOR : DC single phase brushless motor
- FRAME : PBT (94V-0) ; IMPELLER : PBT(94V-0)
- OPERATING TEMP.: -10°C~70°C
- STORAGE TEMP.: -40°C~70°C
- WEIGHT : 11g
- Dual Ball Bearing
- Lead Length: 300mm +/- 10mm
- 2 Wire: Standard
- 3 Wire: Tach (FG) Optional
- 4 Wire: PWM Optional
- IP Rating: IP55 Optional

Description	Size (mm)	Thickness (mm)	Rated Voltage (VDC)	Rated Current (A)	Rated Power (W)	Rated Speed (RPM)	Speed Code	Max Airflow (CFM)	Max Pressure (InAq)	Noise Level (dB/A)	Tach	PWM
DC0351005W2B	35	10	05	0.16	0.80	9000	W	6.30	0.22	28	3	B
DC0351005V2B	35	10	05	0.15	0.75	8000	V	5.51	0.18	25	3	B
DC0351005U2B	35	10	05	0.13	0.65	7000	U	4.37	0.14	23	3	B
DC0351012W2B	35	10	12	0.11	1.30	9000	W	6.30	0.22	28	3	B
DC0351012V2B	35	10	12	0.04	0.48	8000	V	5.51	0.18	25	3	B
DC0351012U2B	35	10	12	0.03	0.36	7000	U	4.37	0.14	23	3	B

See page 6 for termination configurations and typical ordering configurations

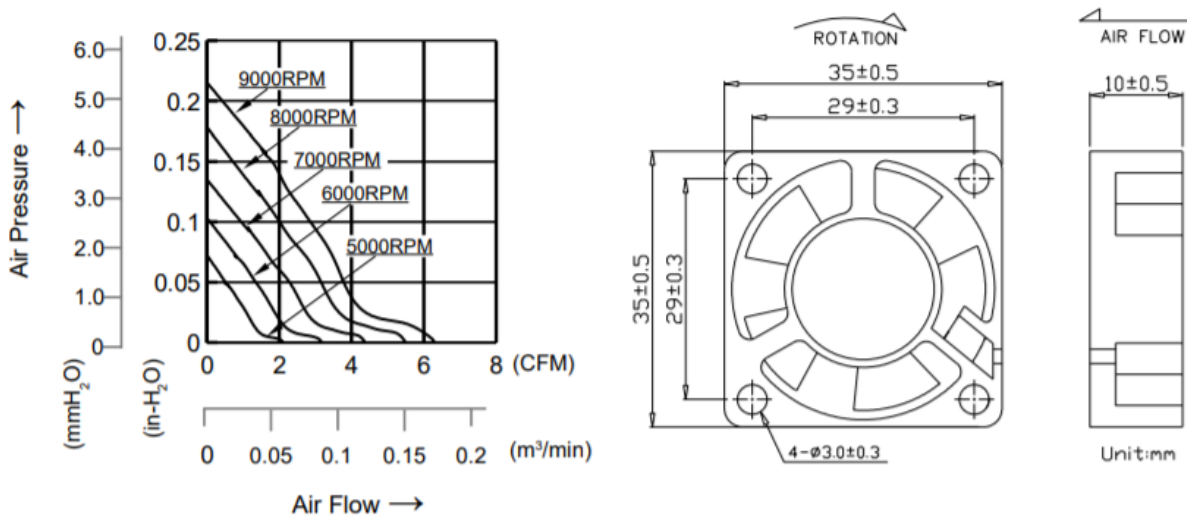

38x38x20mm



- MOTOR : DC single phase brushless motor
- FRAME : PBT (94V-0) ; IMPELLER : PBT(94V-0)
- OPERATING TEMP.: -10°C~70°C
- STORAGE TEMP.: -40°C~70°C
- WEIGHT : 31g
- Dual Ball Bearing
- Lead Length: 300mm +/- 10mm
- 2 Wire: Standard
- 3 Wire: Tach (FG) Optional
- 4 Wire: PWM Optional
- IP Rating: IP55 Optional

Description	Size (mm)	Thickness (mm)	Rated Voltage (VDC)	Rated Current (A)	Rated Power (W)	Rated Speed (RPM)	Speed Code	Max Airflow (CFM)	Max Pressure (InAq)	Noise Level (dB/A)	Tach	PWM
DC0382012U2B	38	20	12	0.30	3.60	10000	U	10.60	0.58	43	3	B
DC0382012H2B	38	20	12	0.13	1.56	8900	H	8.60	0.39	42	3	B
DC0382012M2B	38	20	12	0.12	1.44	8000	M	7.40	0.34	40	3	B
DC0382012L2B	38	20	12	0.10	1.20	6700	L	6.30	0.22	36	3	B
DC0382024U2B	38	20	24	0.12	2.88	10000	U	10.60	0.58	43	3	B
DC0382024H2B	38	20	24	0.11	2.64	8900	H	8.60	0.39	42	3	B
DC0382024M2B	38	20	24	0.10	2.40	8000	M	7.40	0.34	40	3	B
DC0382024L2B	38	20	24	0.09	2.16	6700	L	6.30	0.22	36	3	B

See page 6 for termination configurations and typical ordering configurations

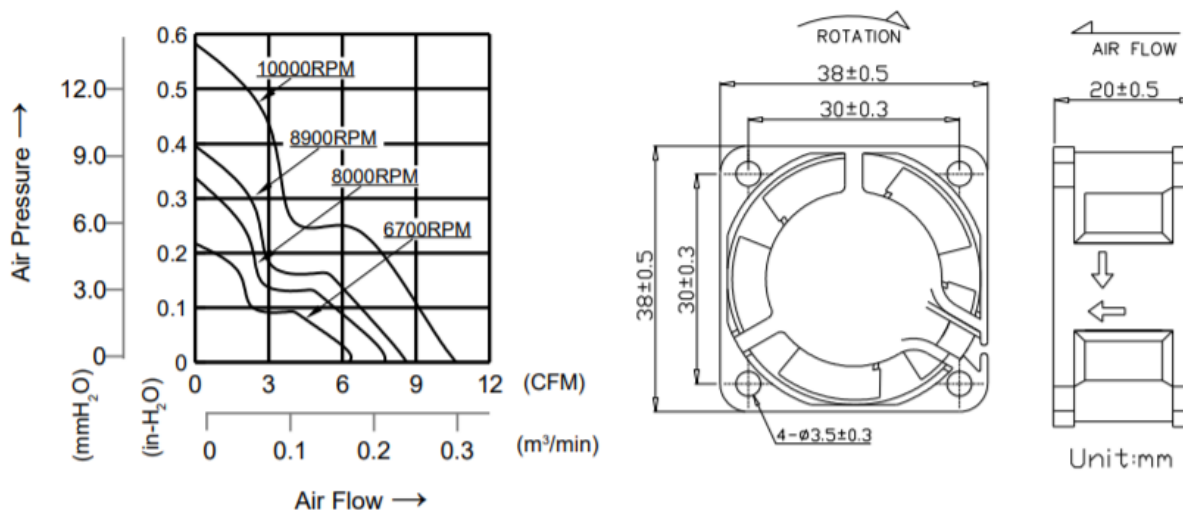

38x38x28mm



- MOTOR : DC single phase brushless motor
- FRAME : PBT (94V-0) ; IMPELLER : PBT(94V-0)
- OPERATING TEMP.: -10°C~70°C
- STORAGE TEMP.: -40°C~70°C
- WEIGHT : 31g
- Dual Ball Bearing
- Lead Length: 300mm +/- 10mm
- 2 Wire: Standard
- 3 Wire: Tach (FG) Optional
- 4 Wire: PWM Optional
- IP Rating: IP55 Optional

Description	Size (mm)	Thickness (mm)	Rated Voltage (VDC)	Rated Current (A)	Rated Power (W)	Rated Speed (RPM)	Speed Code	Max Airflow (CFM)	Max Pressure (InAq)	Noise Level (dB/A)	Tach	PWM
DC0382812V2B	38	28	12	0.85	10.20	17000	V	20.80	1.67	59	3	B
DC0382812U2B	38	28	12	0.48	5.76	15000	U	19.16	1.37	55	3	B
DC0382812H2B	38	28	12	0.29	3.48	13000	H	16.30	1.02	51	3	B
DC0382812M2B	38	28	12	0.30	3.60	10000	M	12.46	0.63	44	3	B
DC0382812L2B	38	28	12	0.11	1.32	8000	L	9.44	0.39	38	3	B

See page 6 for termination configurations and typical ordering configurations

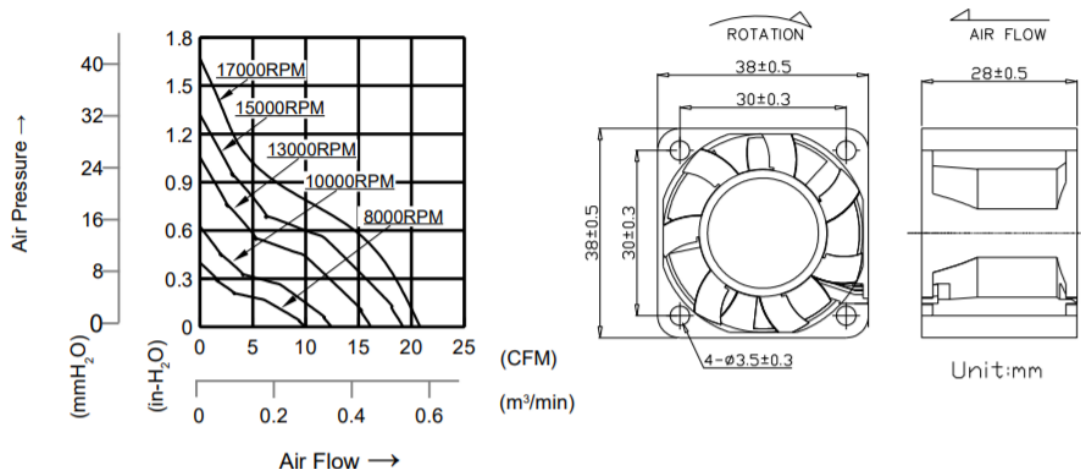

40x40x10mm



- MOTOR : DC single phase brushless motor
- FRAME : PBT (94V-0) ; IMPELLER : PBT(94V-0)
- OPERATING TEMP.: -10°C~70°C
- STORAGE TEMP.: -40°C~70°C
- WEIGHT : 20g
- Dual Ball Bearing
- Lead Length: 300mm +/- 10mm
- 2 Wire: Standard
- 3 Wire: Tach (FG) Optional
- 4 Wire: PWM Optional
- IP Rating: IP55 Optional

Description	Size (mm)	Thickness (mm)	Rated Voltage (VDC)	Rated Current (A)	Rated Power (W)	Rated Speed (RPM)	Speed Code	Max Airflow (CFM)	Max Pressure (InAq)	Noise Level (dB/A)	Tach	PWM
DC0401005V2B	40	10	05	0.40	2.00	10000	V	12.23	0.33	39	3	B
DC0401005U2B	40	10	05	0.20	1.00	8000	U	9.25	0.20	35	3	B
DC0401005H2B	40	10	05	0.11	0.55	6000	H	7.24	0.11	26	3	B
DC0401005M2B	40	10	05	0.05	0.25	4000	M	4.75	0.06	21	3	B
DC0401012V2B	40	10	12	0.17	2.04	10000	V	12.23	0.33	39	3	B
DC0401012U2B	40	10	12	0.09	1.08	8000	U	9.25	0.20	35	3	B
DC0401012H2B	40	10	12	0.06	0.72	6000	H	7.24	0.11	26	3	B
DC0401012M2B	40	10	12	0.03	0.36	4000	M	4.75	0.06	21	3	B
DC0401024V2B	40	10	24	0.09	2.16	10000	V	12.23	0.33	39	3	B
DC0401024U2B	40	10	24	0.06	1.44	8000	U	9.25	0.20	35	3	B
DC0401024H2B	40	10	24	0.03	0.72	6000	H	7.24	0.11	26	3	B
DC0401024M2B	40	10	24	0.02	0.48	4000	M	4.75	0.06	21	3	B

See page 6 for termination configurations and typical ordering configurations

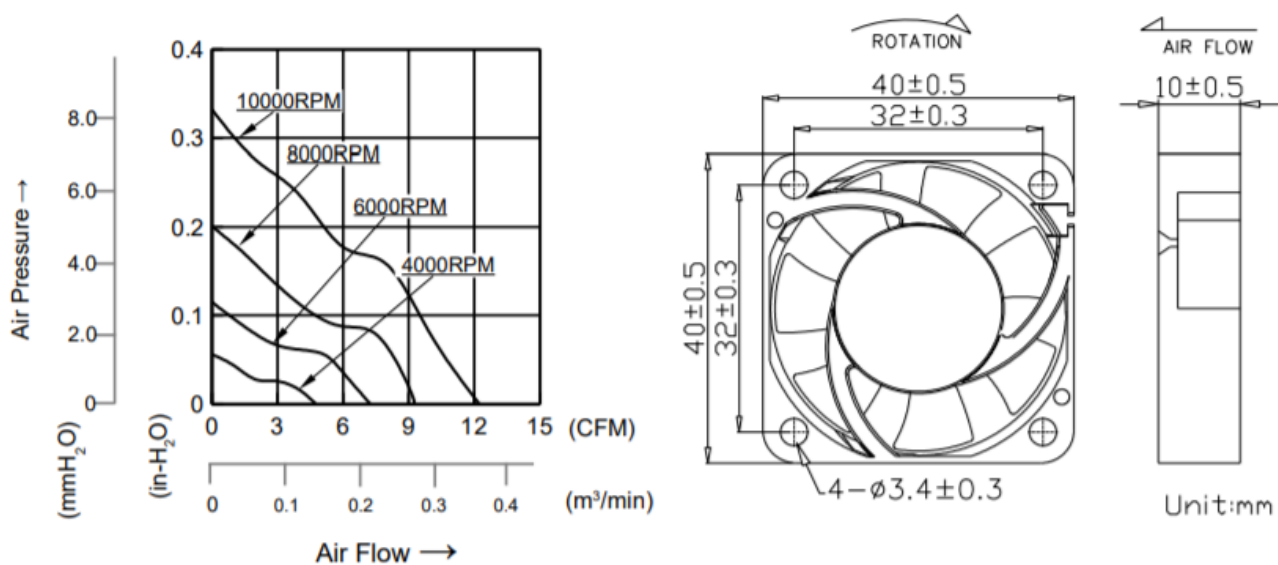

40x40x15mm



- MOTOR : DC single phase brushless motor
- FRAME : PBT (94V-0) ; IMPELLER : PBT(94V-0)
- OPERATING TEMP.: -10°C~70°C
- STORAGE TEMP.: -40°C~70°C
- WEIGHT : 20g
- Dual Ball Bearing
- Lead Length: 300mm +/- 10mm
- 2 Wire: Standard
- 3 Wire: Tach (FG) Optional
- 4 Wire: PWM Optional
- IP Rating: IP55 Optional

Description	Size (mm)	Thickness (mm)	Rated Voltage (VDC)	Rated Current (A)	Rated Power (W)	Rated Speed (RPM)	Speed Code	Max Airflow (CFM)	Max Pressure (InAq)	Noise Level (dB/A)	Tach	PWM
DC0401512H2B	40	15	12	0.16	1.92	8600	H	10.45	0.38	36	3	B
DC0401512L2B	40	15	12	0.08	0.96	6000	L	6.71	0.20	28	3	B
DC0401512M2B	40	15	12	0.12	1.44	7300	M	8.25	0.29	32	3	B
DC0401524H2B	40	15	24	0.05	1.20	8600	H	10.45	0.38	36	3	B
DC0401524L2B	40	15	24	0.03	0.72	6000	L	6.71	0.20	28	3	B
DC0401524M2B	40	15	24	0.04	0.96	7300	M	8.25	0.29	32	3	B

See page 6 for termination configurations and typical ordering configurations

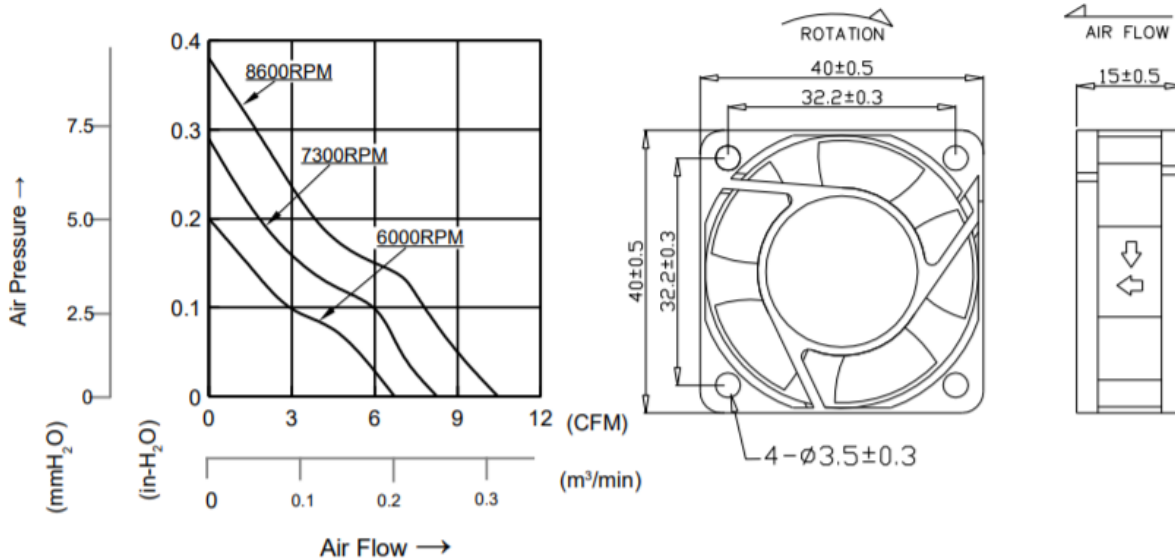

40x40x20mm



- MOTOR : DC single phase brushless motor
- FRAME : PBT (94V-0) ; IMPELLER : PBT(94V-0)
- OPERATING TEMP.: -10°C~70°C
- STORAGE TEMP.: -40°C~70°C
- WEIGHT : 20g
- Dual Ball Bearing
- Lead Length: 300mm +/- 10mm
- 2 Wire: Standard
- 3 Wire: Tach (FG) Optional
- 4 Wire: PWM Optional
- IP Rating: IP55 Optional

Description	Size (mm)	Thickness (mm)	Rated Voltage (VDC)	Rated Current (A)	Rated Power (W)	Rated Speed (RPM)	Speed Code	Max Airflow (CFM)	Max Pressure (InAq)	Noise Level (dB/A)	Tach	PWM
DC0402012V2B	40	20	12	0.41	4.92	16000	V	19.80	1.44	53	3	B
DC0402012U2B	40	20	12	0.25	3.00	14000	U	16.80	1.08	49	3	B
DC0402012H2B	40	20	12	0.17	2.04	12000	H	14.30	0.79	44	3	B
DC0402012M2B	40	20	12	0.11	1.32	10000	M	11.70	0.55	40	3	B
DC0402012L2B	40	20	12	0.08	0.96	8000	L	9.40	0.35	33	3	B
DC0402024V2B	40	20	24	0.26	6.24	16000	V	19.80	1.44	53	3	B
DC0402024U2B	40	20	24	0.23	5.52	14000	U	16.80	1.08	49	3	B
DC0402024H2B	40	20	24	0.16	3.84	12000	H	14.30	0.79	44	3	B
DC0402024M2B	40	20	24	0.11	2.64	10000	M	11.70	0.55	40	3	B
DC0402024L2B	40	20	24	0.10	2.40	8000	L	9.40	0.35	33	3	B

See page 6 for termination configurations and typical ordering configurations

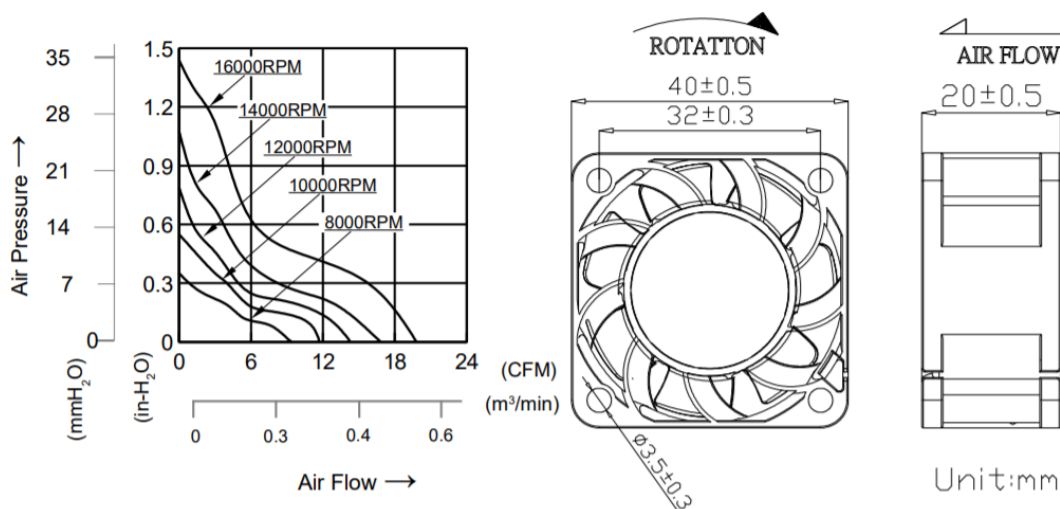

40x40x28mm and 40x40x56mm



- MOTOR : DC single phase brushless motor
- FRAME : PBT (94V-0) ; IMPELLER : PBT(94V-0)
- OPERATING TEMP.: -10°C~70°C
- STORAGE TEMP.: -40°C~70°C
- WEIGHT : 49-85g
- Dual Ball Bearing
- Lead Length: 300mm +/- 10mm
- 2 Wire: Standard
- 3 Wire: Tach (FG) Optional
- 4 Wire: PWM Optional
- IP Rating: IP55 Optional

Description	Size (mm)	Thickness (mm)	Rated Voltage (VDC)	Rated Current (A)	Rated Power (W)	Rated Speed (RPM)	Speed Code	Max Airflow (CFM)	Max Pressure (InAq)	Noise Level (dB/A)	Tach	PWM
DC0402812W2B	40	28	12	1.40	16.80	23000	W	31.30	3.02	64	3	B
DC0402812V2B	40	28	12	1.10	13.20	21000	V	29.50	2.89	62	3	B
DC0402812U2B	40	28	12	0.64	7.68	15000	U	24.80	1.64	58	3	B
DC0402812H2B	40	28	12	0.55	6.60	13000	H	23.80	1.32	54	3	B
DC0402812M2B	40	28	12	0.65	7.80	11000	M	18.70	0.92	51	3	B
DC0402812L2B	40	28	12	0.24	2.88	9500	L	15.90	0.69	44	3	B
DC0402824U2B	40	28	24	0.31	7.44	15000	U	24.80	1.64	58	3	B
DC0402824H2B	40	28	24	0.28	6.72	13000	H	23.80	1.32	54	3	B
DC0402824M2B	40	28	24	0.15	3.60	11000	M	18.70	0.92	51	3	B
DC0402824L2B	40	28	24	0.11	2.64	9500	L	15.90	0.69	44	3	B
DC0402824W2B	40	28	24	0.64	15.36	23000	W	31.30	3.02	64	3	B
DC0402824V2B	40	28	24	0.50	12.00	21000	V	29.50	2.89	62	3	B
DC0405612U2B	40	56	12	1.72	20.64	21000	U	37.21	3.87	69	3	B

See page 6 for termination configurations and typical ordering configurations



40x40x28mm and 40x40x56mm

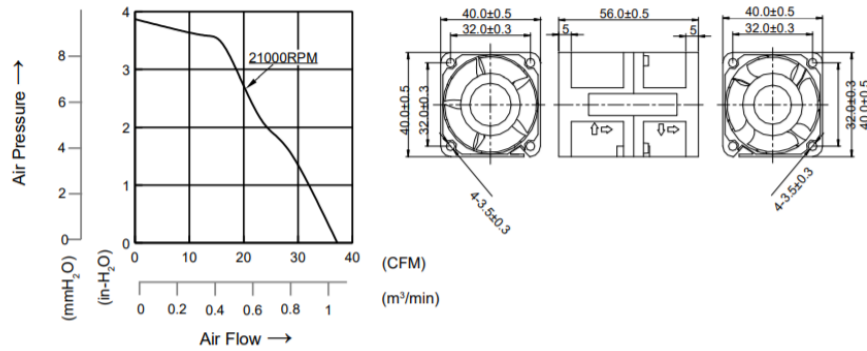
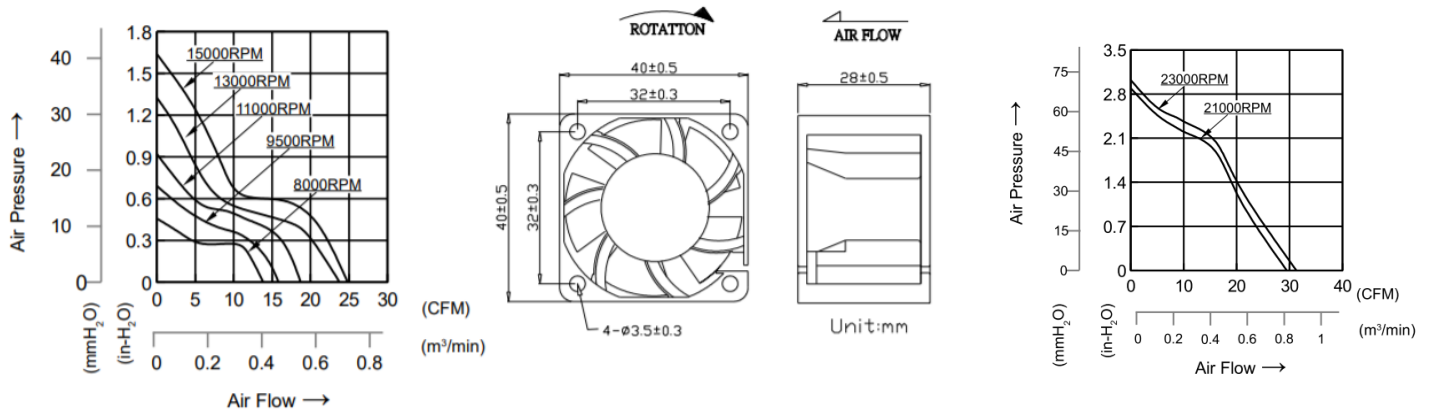

50x50x10mm



- MOTOR : DC single phase brushless motor
- FRAME : PBT (94V-0) ; IMPELLER : PBT(94V-0)
- OPERATING TEMP.: -10°C~70°C
- STORAGE TEMP.: -40°C~70°C
- WEIGHT : 32g
- Dual Ball Bearing
- Lead Length: 300mm +/- 10mm
- 2 Wire: Standard
- 3 Wire: Tach (FG) Optional
- 4 Wire: PWM Optional
- IP Rating: IP55 Optional

Description	Size (mm)	Thickness (mm)	Rated Voltage (VDC)	Rated Current (A)	Rated Power (W)	Rated Speed (RPM)	Speed Code	Max Airflow (CFM)	Max Pressure (InAq)	Noise Level (dB/A)	Tach	PWM
DC0501005H2B	50	10	05	0.16	0.80	6500	H	12.70	0.18	35	3	B
DC0501005M2B	50	10	05	0.12	0.60	5500	M	10.50	0.14	30	3	B
DC0501005L2B	50	10	05	0.07	0.35	4500	L	8.20	0.09	25	3	B
DC0501005J2B	50	10	05	0.06	0.30	3500	J	6.70	0.05	18	3	B
DC0501012H2B	50	10	12	0.10	1.20	6500	H	12.70	0.18	35	3	B
DC0501012M2B	50	10	12	0.08	0.96	5500	M	10.50	0.14	30	3	B
DC0501012L2B	50	10	12	0.07	0.84	4500	L	8.20	0.09	25	3	B
DC0501012J2B	50	10	12	0.05	0.60	3500	J	6.70	0.05	18	3	B
DC0501024H2B	50	10	24	0.05	1.20	6500	H	12.70	0.18	35	3	B
DC0501024M2B	50	10	24	0.04	0.96	5500	M	10.50	0.14	30	3	B
DC0501024L2B	50	10	24	0.03	0.72	4500	L	8.20	0.09	25	3	B
DC0501024J2B	50	10	24	0.02	0.48	3500	J	6.70	0.05	18	3	B

See page 6 for termination configurations and typical ordering configurations

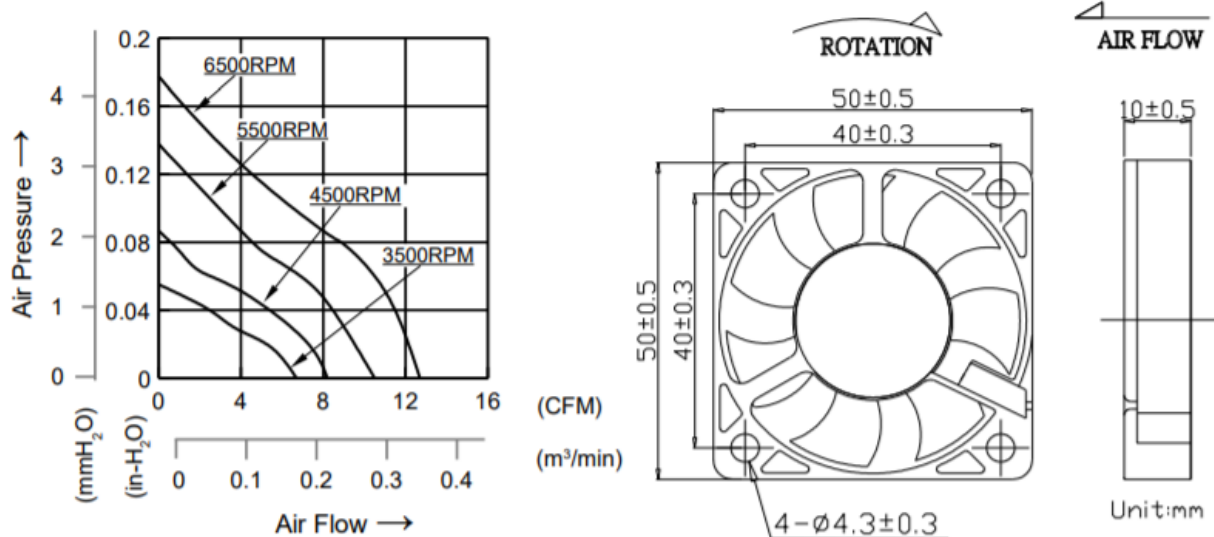

50x50x15mm



- MOTOR : DC single phase brushless motor
- FRAME : PBT (94V-0) ; IMPELLER : PBT(94V-0)
- OPERATING TEMP.: -10°C~70°C
- STORAGE TEMP.: -40°C~70°C
- WEIGHT : 38g
- Dual Ball Bearing
- Lead Length: 300mm +/- 10mm
- 2 Wire: Standard
- 3 Wire: Tach (FG) Optional
- 4 Wire: PWM Optional
- IP Rating: IP55 Optional

Description	Size (mm)	Thickness (mm)	Rated Voltage (VDC)	Rated Current (A)	Rated Power (W)	Rated Speed (RPM)	Speed Code	Max Airflow (CFM)	Max Pressure (InAq)	Noise Level (dB/A)	Tach	PWM
DC0501512U2B	50	15	12	0.13	1.56	6000	U	17.00	0.23	36	3	B
DC0501512H2B	50	15	12	0.11	1.32	5400	H	15.00	0.18	32	3	B
DC0501512M2B	50	15	12	0.09	1.08	4800	M	13.20	0.16	30	3	B
DC0501512L2B	50	15	12	0.07	0.84	4200	L	12.20	0.12	27	3	B
DC0501512J2B	50	15	12	0.06	0.72	3600	J	9.90	0.08	24	3	B
DC0501524U2B	50	15	24	0.06	1.44	6000	U	17.00	0.23	36	3	B
DC0501524H2B	50	15	24	0.05	1.20	5400	H	15.00	0.18	32	3	B
DC0501524M2B	50	15	24	0.04	0.96	4800	M	13.20	0.16	30	3	B
DC0501524L2B	50	15	24	0.03	0.72	4200	L	12.20	0.12	27	3	B
DC0501524J2B	50	15	24	0.02	0.48	3600	J	9.90	0.08	24	3	B

See page 6 for termination configurations and typical ordering configurations

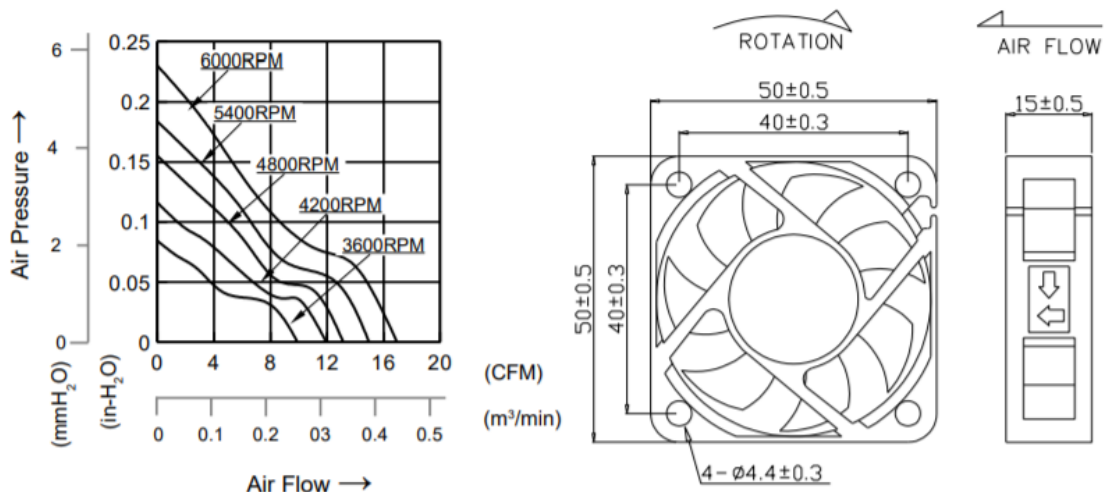

50x50x20mm



- MOTOR : DC single phase brushless motor
- FRAME : PBT (94V-0) ; IMPELLER : PBT(94V-0)
- OPERATING TEMP.: -10°C~70°C
- STORAGE TEMP.: -40°C~70°C
- WEIGHT : 40g
- Dual Ball Bearing
- Lead Length: 300mm +/- 10mm
- 2 Wire: Standard
- 3 Wire: Tach (FG) Optional
- 4 Wire: PWM Optional
- IP Rating: IP55 Optional

Description	Size (mm)	Thickness (mm)	Rated Voltage (VDC)	Rated Current (A)	Rated Power (W)	Rated Speed (RPM)	Speed Code	Max Airflow (CFM)	Max Pressure (InAq)	Noise Level (dB/A)	Tach	PWM
DC0502012H2B	50	20	12	0.30	3.60	7000	H	20.30	0.30	38	3	B
DC0502012M2B	50	20	12	0.21	2.52	6400	M	17.60	0.25	36	3	B
DC0502012L2B	50	20	12	0.15	1.80	5600	L	14.80	0.18	32	3	B
DC0502012J2B	50	20	12	0.13	1.56	4800	J	12.70	0.14	28	3	B
DC0502012I2B	50	20	12	0.10	1.20	4000	I	10.10	0.10	24	3	B
DC0502024H2B	50	20	24	0.15	3.60	7000	H	20.30	0.30	38	3	B
DC0502024M2B	50	20	24	0.13	3.12	6400	M	17.60	0.25	36	3	B
DC0502024L2B	50	20	24	0.11	2.64	5600	L	14.80	0.18	32	3	B
DC0502024J2B	50	20	24	0.06	1.44	4800	J	12.70	0.14	28	3	B
DC0502024I2B	50	20	24	0.04	0.96	4000	I	10.10	0.10	24	3	B

See page 6 for termination configurations and typical ordering configurations

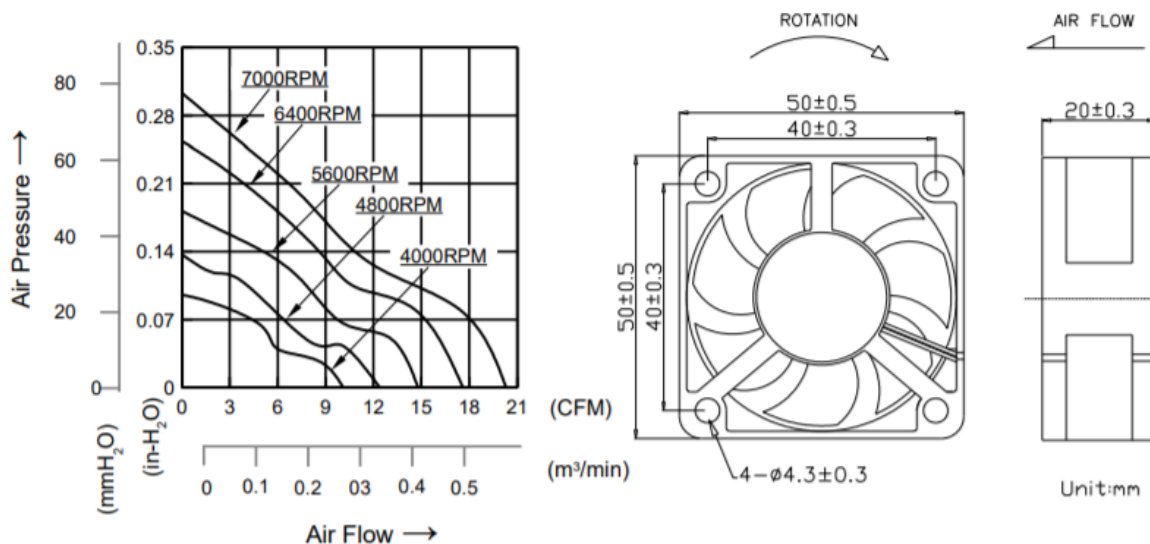

60x60x10mm



- MOTOR : DC single phase brushless motor
- FRAME : PBT (94V-0) ; IMPELLER : PBT(94V-0)
- OPERATING TEMP.: -10°C~70°C
- STORAGE TEMP.: -40°C~70°C
- WEIGHT : 40g
- Dual Ball Bearing
- Lead Length: 300mm +/- 10mm
- 2 Wire: Standard
- 3 Wire: Tach (FG) Optional
- 4 Wire: PWM Optional
- IP Rating: IP55 Optional

Description	Size (mm)	Thickness (mm)	Rated Voltage (VDC)	Rated Current (A)	Rated Power (W)	Rated Speed (RPM)	Speed Code	Max Airflow (CFM)	Max Pressure (InAq)	Noise Level (dB/A)	Tach	PWM
DC0601005U2B	60	10	05	0.31	1.55	4900	U	19.90	0.16	37	3	B
DC0601005M2B	60	10	05	0.28	1.40	4200	M	17.10	0.12	33	3	B
DC0601012U2B	60	10	12	0.20	2.40	4900	U	19.90	0.16	37	3	B
DC0601012M2B	60	10	12	0.17	2.04	4200	M	17.10	0.12	33	3	B
DC0601024U2B	60	10	24	0.14	3.36	4900	U	19.90	0.16	37	3	B
DC0601024M2B	60	10	24	0.11	2.64	4200	M	17.10	0.12	33	3	B

See page 6 for termination configurations and typical ordering configurations

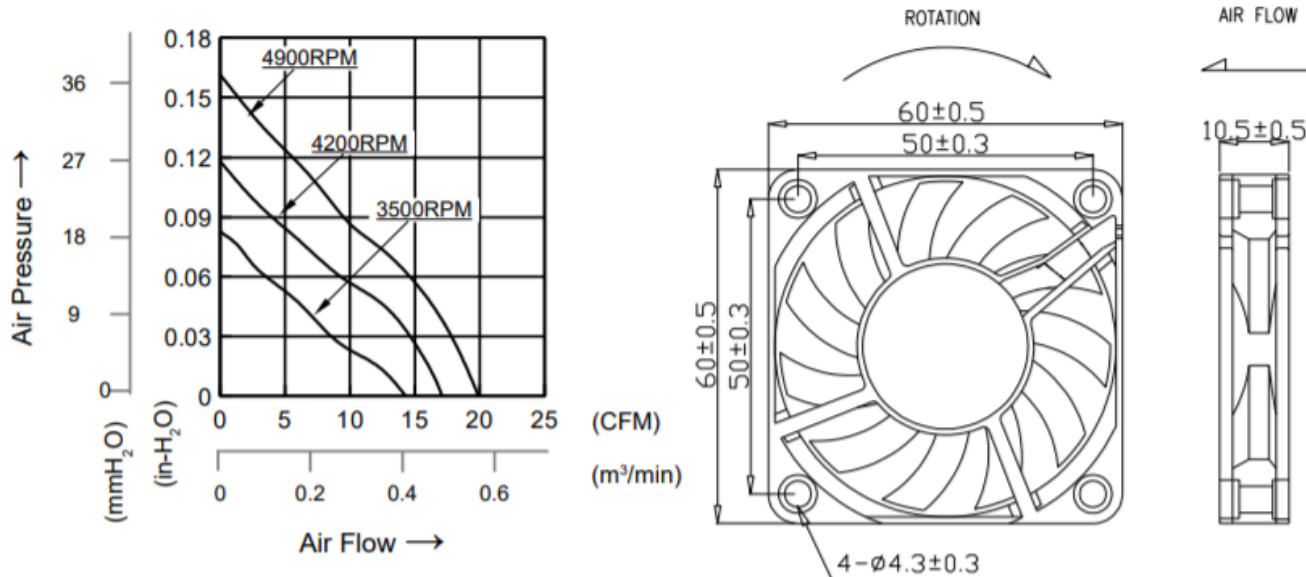

60x60x15mm



- MOTOR : DC single phase brushless motor
- FRAME : PBT (94V-0) ; IMPELLER : PBT(94V-0)
- OPERATING TEMP.: -10°C~70°C
- STORAGE TEMP.: -40°C~70°C
- WEIGHT : 44g
- Dual Ball Bearing
- Lead Length: 300mm +/- 10mm
- 2 Wire: Standard
- 3 Wire: Tach (FG) Optional
- 4 Wire: PWM Optional
- IP Rating: IP55 Optional

Description	Size (mm)	Thickness (mm)	Rated Voltage (VDC)	Rated Current (A)	Rated Power (W)	Rated Speed (RPM)	Speed Code	Max Airflow (CFM)	Max Pressure (InAq)	Noise Level (dB/A)	Tach	PWM
DC0601512U2B	60	15	12	0.26	3.12	5000	U	26.50	0.23	37	3	B
DC0601512H2B	60	15	12	0.12	1.44	4500	H	23.10	0.18	35	3	B
DC0601512M2B	60	15	12	0.10	1.20	4000	M	21.70	0.16	32	3	B
DC0601512L2B	60	15	12	0.08	0.96	3500	L	19.00	0.14	29	3	B
DC0601512J2B	60	15	12	0.06	0.72	3000	J	15.00	0.09	24	3	B
DC0601524U2B	60	15	24	0.11	2.64	5000	U	26.50	0.23	37	3	B
DC0601524H2B	60	15	24	0.10	2.40	4500	H	23.10	0.18	35	3	B
DC0601524M2B	60	15	24	0.08	1.92	4000	M	21.70	0.16	32	3	B
DC0601524L2B	60	15	24	0.06	1.44	3500	L	19.00	0.14	29	3	B
DC0601524J2B	60	15	24	0.05	1.20	3000	J	15.00	0.09	24	3	B

See page 6 for termination configurations and typical ordering configurations

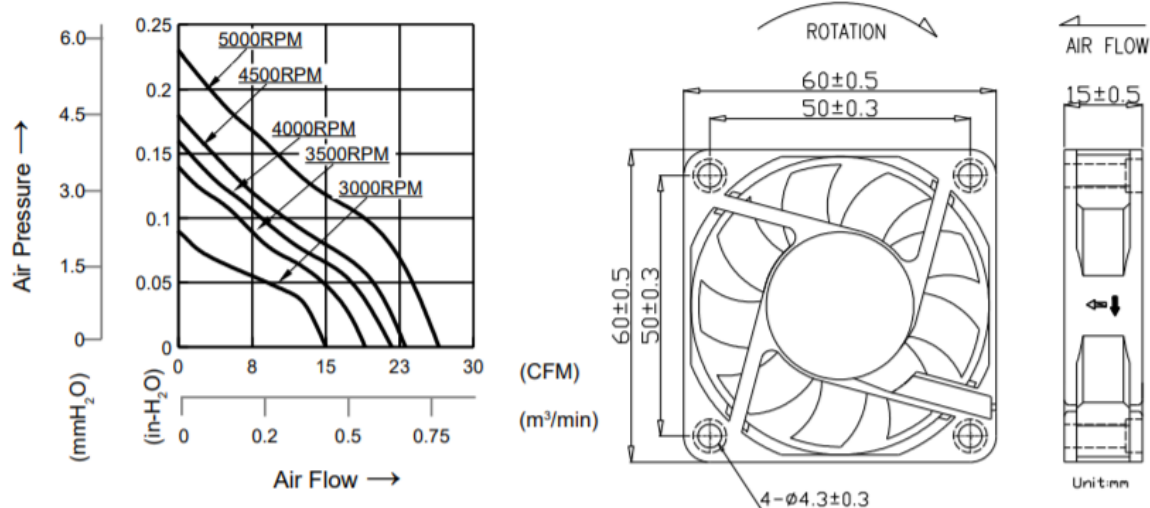

60x60x20mm



- MOTOR : DC single phase brushless motor
- FRAME : PBT (94V-0) ; IMPELLER : PBT(94V-0)
- OPERATING TEMP.: -10°C~70°C
- STORAGE TEMP.: -40°C~70°C
- WEIGHT : 50g
- Dual Ball Bearing
- Lead Length: 300mm +/- 10mm
- 2 Wire: Standard
- 3 Wire: Tach (FG) Optional
- 4 Wire: PWM Optional
- IP Rating: IP55 Optional

Description	Size (mm)	Thickness (mm)	Rated Voltage (VDC)	Rated Current (A)	Rated Power (W)	Rated Speed (RPM)	Speed Code	Max Airflow (CFM)	Max Pressure (InAq)	Noise Level (dB/A)	Tach	PWM
DC0602012U2B	60	20	12	0.14	1.73	4800	U	19.60	0.27	33	3	B
DC0602012H2B	60	20	12	0.12	1.44	4400	H	18.10	0.23	31	3	B
DC0602012M2B	60	20	12	0.11	1.32	4000	M	16.40	0.19	29	3	B
DC0602012L2B	60	20	12	0.09	1.08	3600	L	14.80	0.15	26	3	B
DC0602012J2B	60	20	12	0.07	0.84	3200	J	13.50	0.12	24	3	B
DC0602024U2B	60	20	24	0.09	2.16	4800	U	19.60	0.27	33	3	B
DC0602024H2B	60	20	24	0.08	1.92	4400	H	18.10	0.23	31	3	B
DC0602024M2B	60	20	24	0.07	1.68	4000	M	16.40	0.19	29	3	B
DC0602024L2B	60	20	24	0.06	1.44	3600	L	14.80	0.15	26	3	B
DC0602024J2B	60	20	24	0.05	1.20	3200	J	13.50	0.12	24	3	B

See page 6 for termination configurations and typical ordering configurations

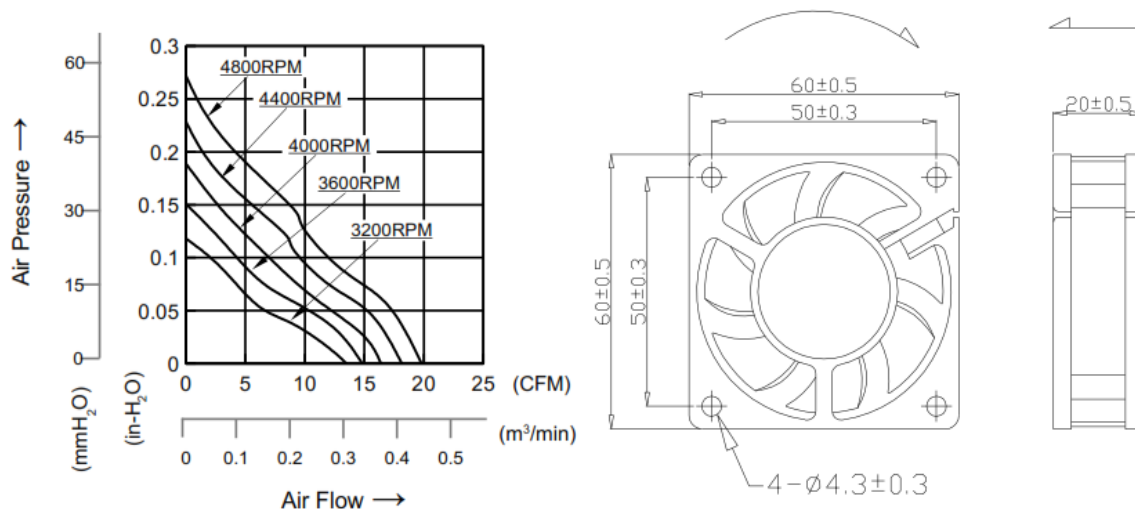

60x60x25mm



- MOTOR : DC single phase brushless motor
- FRAME : PBT (94V-0) ; IMPELLER : PBT(94V-0)
- OPERATING TEMP.: -10°C~70°C
- STORAGE TEMP.: -40°C~70°C
- WEIGHT : 57g
- Dual Ball Bearing
- Lead Length: 300mm +/- 10mm
- 2 Wire: Standard
- 3 Wire: Tach (FG) Optional
- 4 Wire: PWM Optional
- IP Rating: IP55 Optional

Description	Size (mm)	Thickness (mm)	Rated Voltage (VDC)	Rated Current (A)	Rated Power (W)	Rated Speed (RPM)	Speed Code	Max Airflow (CFM)	Max Pressure (InAq)	Noise Level (dB/A)	Tach	PWM
DC0602512W2B	60	25	12	0.95	11.40	9800	W	55.50	1.17	66	3	B
DC0602512V2B	60	25	12	0.48	5.76	7500	V	47.90	0.79	63	3	B
DC0602512U2B	60	25	12	0.37	4.44	6800	U	43.80	0.56	56	3	B
DC0602512H2B	60	25	12	0.17	2.04	5000	H	33.60	0.25	40	3	B
DC0602512M2B	60	25	12	0.12	1.44	4250	M	24.00	0.22	34	3	B
DC0602512L2B	60	25	12	0.09	1.08	3600	L	21.50	0.16	31	3	B
DC0602512J2B	60	25	12	0.07	0.84	3100	J	17.10	0.12	26	3	B
DC0602524W2B	60	25	24	0.44	10.56	9800	W	55.50	1.17	66	3	B
DC0602524V2B	60	25	24	0.24	5.76	7500	V	47.90	0.79	63	3	B
DC0602524U2B	60	25	24	0.18	4.32	6800	U	43.80	0.56	56	3	B
DC0602524H2B	60	25	24	0.09	2.16	5000	H	33.60	0.25	40	3	B
DC0602524M2B	60	25	24	0.07	1.68	4250	M	24.00	0.22	34	3	B
DC0602524L2B	60	25	24	0.05	1.20	3600	L	21.50	0.16	31	3	B
DC0602524J2B	60	25	24	0.04	0.96	3100	J	17.10	0.12	26	3	B
DC0602548W2B	60	25	48	0.30	14.40	9800	W	55.50	1.17	66	3	B
DC0602548V2B	60	25	48	0.14	6.72	7500	V	47.90	0.79	63	3	B
DC0602548U2B	60	25	48	0.12	5.76	6800	U	43.80	0.56	56	3	B
DC0602548H2B	60	25	48	0.06	2.88	5000	H	33.60	0.25	40	3	B
DC0602548M2B	60	25	48	0.05	2.40	4250	M	24.00	0.22	34	3	B
DC0602548L2B	60	25	48	0.04	1.92	3600	L	21.50	0.16	31	3	B
DC0602548J2B	60	25	48	0.03	1.44	3100	J	17.10	0.12	26	3	B

See page 6 for termination configurations and typical ordering configurations



60x60x25mm

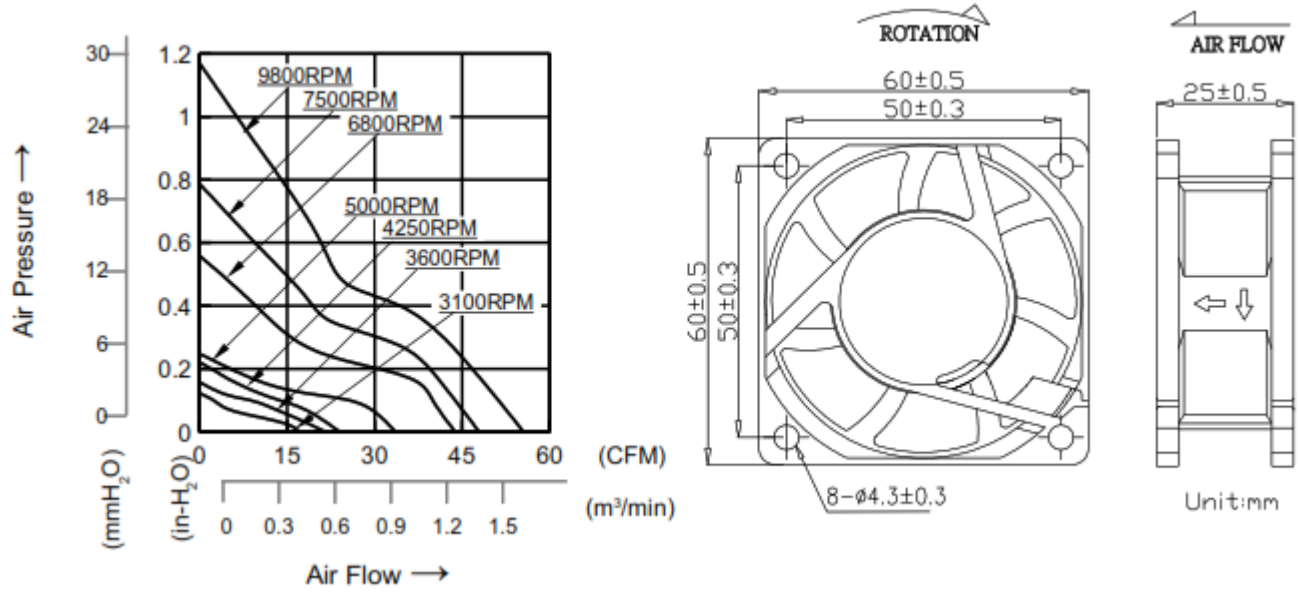

60x60x38mm



- MOTOR : DC single phase brushless motor
- FRAME : PBT (94V-0) ; IMPELLER : PBT(94V-0)
- OPERATING TEMP.: -10°C~70°C
- STORAGE TEMP.: -40°C~70°C
- WEIGHT : 145g
- Dual Ball Bearing
- Lead Length: 300mm +/- 10mm
- 2 Wire: Standard
- 3 Wire: Tach (FG) Optional
- 4 Wire: PWM Optional
- IP Rating: IP55 Optional

Description	Size (mm)	Thickness (mm)	Rated Voltage (VDC)	Rated Current (A)	Rated Power (W)	Rated Speed (RPM)	Speed Code	Max Airflow (CFM)	Max Pressure (InAq)	Noise Level (dB/A)	Tach	PWM
DC0603812M2B	60	38	12	1.38	16.56	12000	M	67.30	2.07	62	3	B
DC0603812L2B	60	38	12	1.00	12.00	10000	L	55.20	1.41	57	3	B
DC0603812J2B	60	38	12	0.68	8.16	9000	J	50.80	1.19	54	3	B
DC0603812I2B	60	38	12	0.52	6.24	8000	I	43.10	0.90	51	3	B
DC0603824M2B	60	38	24	0.75	18.00	12000	M	67.30	2.07	62	3	B
DC0603824L2B	60	38	24	0.50	12.00	10000	L	55.20	1.41	57	3	B
DC0603824J2B	60	38	24	0.41	9.84	9000	J	50.80	1.19	54	3	B
DC0603824I2B	60	38	24	0.33	7.92	8000	I	43.10	0.90	51	3	B
DC0603848M2B	60	38	48	0.36	17.28	12000	M	67.30	2.07	62	3	B
DC0603848L2B	60	38	48	0.28	13.44	10000	L	55.20	1.41	57	3	B
DC0603848J2B	60	38	48	0.23	11.04	9000	J	50.80	1.19	54	3	B
DC0603848I2B	60	38	48	0.19	9.12	8000	I	43.10	0.90	51	3	B

See page 6 for termination configurations and typical ordering configurations

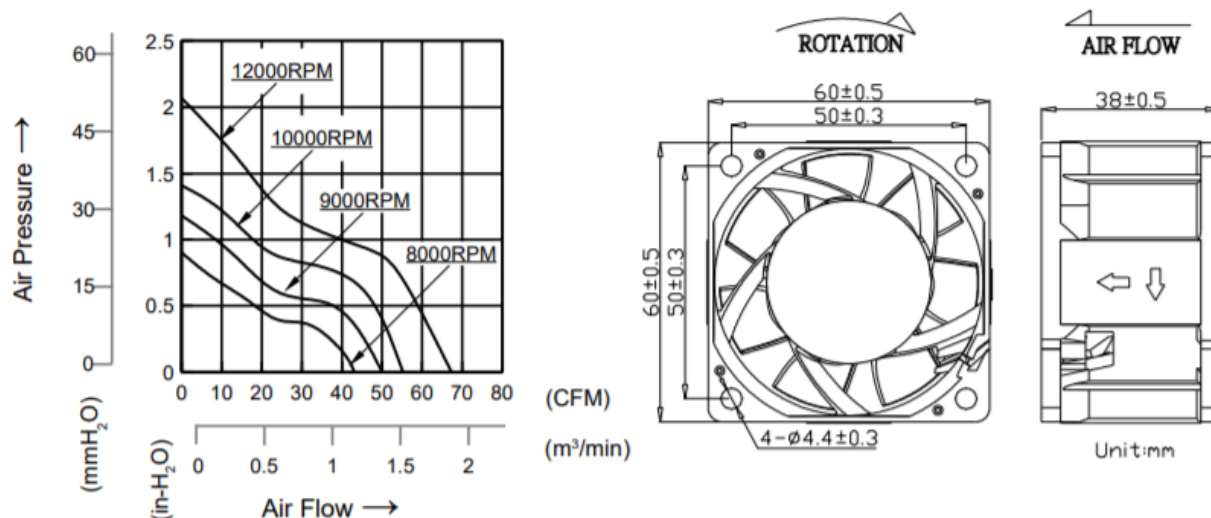

70x70x15mm



- MOTOR : DC single phase brushless motor
- FRAME : PBT (94V-0) ; IMPELLER : PBT(94V-0)
- OPERATING TEMP.: -10°C~70°C
- STORAGE TEMP.: -40°C~70°C
- WEIGHT : 50g
- Dual Ball Bearing
- Lead Length: 300mm +/- 10mm
- 2 Wire: Standard
- 3 Wire: Tach (FG) Optional
- 4 Wire: PWM Optional
- IP Rating: IP55 Optional

Description	Size (mm)	Thickness (mm)	Rated Voltage (VDC)	Rated Current (A)	Rated Power (W)	Rated Speed (RPM)	Speed Code	Max Airflow (CFM)	Max Pressure (InAq)	Noise Level (dB/A)	Tach	PWM
DC0701512H2B	70	15	12	0.25	3.00	4300	H	33.50	0.22	39	3	B
DC0701512M2B	70	15	12	0.17	2.04	3800	M	29.60	0.17	35	3	B
DC0701512L2B	70	15	12	0.12	1.44	3300	L	25.70	0.13	31	3	B
DC0701512J2B	70	15	12	0.10	1.20	2800	J	21.10	0.09	27	3	B
DC0701524H2B	70	15	24	0.12	2.88	4300	H	33.50	0.22	39	3	B
DC0701524M2B	70	15	24	0.10	2.40	3800	M	29.60	0.17	35	3	B
DC0701524L2B	70	15	24	0.09	2.16	3300	L	25.70	0.13	31	3	B
DC0701524J2B	70	15	24	0.08	1.92	2800	J	21.10	0.09	27	3	B

See page 6 for termination configurations and typical ordering configurations

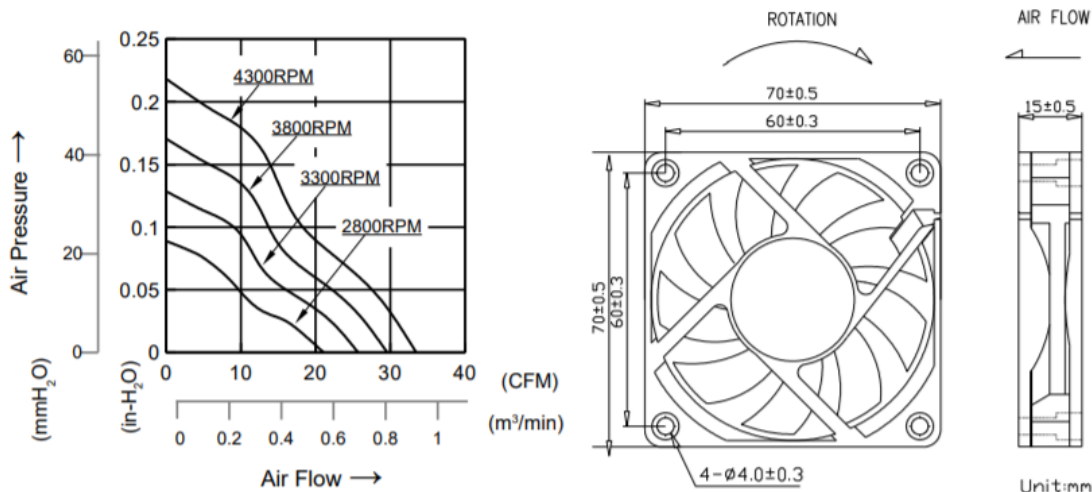

70x70x25mm



- MOTOR : DC single phase brushless motor
- FRAME : PBT (94V-0) ; IMPELLER : PBT(94V-0)
- OPERATING TEMP.: -10°C~70°C
- STORAGE TEMP.: -40°C~70°C
- WEIGHT : 74g
- Dual Ball Bearing
- Lead Length: 300mm +/- 10mm
- 2 Wire: Standard
- 3 Wire: Tach (FG) Optional
- 4 Wire: PWM Optional
- IP Rating: IP55 Optional

Description	Size (mm)	Thickness (mm)	Rated Voltage (VDC)	Rated Current (A)	Rated Power (W)	Rated Speed (RPM)	Speed Code	Max Airflow (CFM)	Max Pressure (InAq)	Noise Level (dB/A)	Tach	PWM
DC0702512U2B	70	25	12	0.27	3.24	5500	U	54.80	0.50	45	3	B
DC0702512H2B	70	25	12	0.13	1.56	4000	H	39.90	0.27	37	3	B
DC0702512M2B	70	25	12	0.09	1.08	3600	M	35.60	0.22	32	3	B
DC0702512L2B	70	25	12	0.07	0.84	3000	L	30.00	0.15	27	3	B
DC0702524U2B	70	25	24	0.15	3.60	5500	U	54.80	0.50	45	3	B
DC0702524H2B	70	25	24	0.10	2.40	4000	H	39.90	0.27	37	3	B
DC0702524M2B	70	25	24	0.08	1.92	3600	M	35.60	0.22	32	3	B
DC0702524L2B	70	25	24	0.06	1.44	3000	L	30.00	0.15	27	3	B
DC0702548U2B	70	25	48	0.09	4.32	5500	U	54.80	0.50	45	3	B
DC0702548H2B	70	25	48	0.07	3.36	4000	H	39.90	0.27	37	3	B
DC0702548M2B	70	25	48	0.05	2.40	3600	M	35.60	0.22	32	3	B
DC0702548L2B	70	25	48	0.04	1.92	3000	L	30.00	0.15	27	3	B

See page 6 for termination configurations and typical ordering configurations

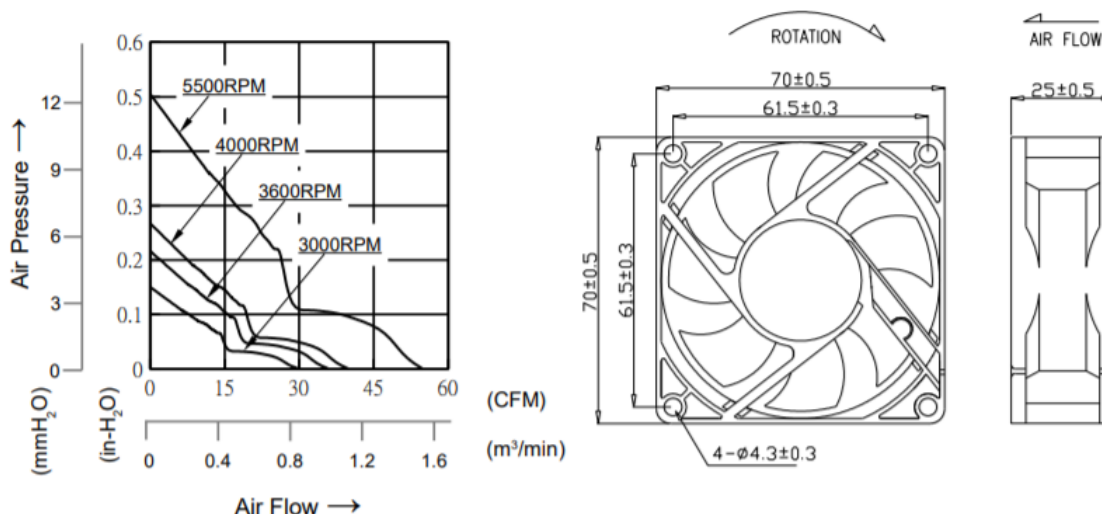

80x80x15mm



- MOTOR : DC single phase brushless motor
- FRAME : PBT (94V-0) ; IMPELLER : PBT(94V-0)
- OPERATING TEMP.: -10°C~70°C
- STORAGE TEMP.: -40°C~70°C
- WEIGHT : 54g
- Dual Ball Bearing
- Lead Length: 300mm +/- 10mm
- 2 Wire: Standard
- 3 Wire: Tach (FG) Optional
- 4 Wire: PWM Optional
- IP Rating: IP55 Optional

Description	Size (mm)	Thickness (mm)	Rated Voltage (VDC)	Rated Current (A)	Rated Power (W)	Rated Speed (RPM)	Speed Code	Max Airflow (CFM)	Max Pressure (InAq)	Noise Level (dB/A)	Tach	PWM
DC0801512U2B	80	15	12	0.48	5.76	4500	U	45.20	0.21	43	3	B
DC0801512H2B	80	15	12	0.16	1.92	3600	H	37.60	0.15	36	3	B
DC0801512M2B	80	15	12	0.12	1.44	3100	M	31.50	0.10	32	3	B
DC0801512L2B	80	15	12	0.10	1.20	2700	L	27.50	0.09	30	3	B
DC0801512J2B	80	15	12	0.06	0.72	2400	J	22.00	0.05	25	3	B
DC0801524U2B	80	15	24	0.18	4.32	4500	U	45.20	0.21	43	3	B
DC0801524H2B	80	15	24	0.12	2.88	3600	H	37.60	0.15	36	3	B
DC0801524M2B	80	15	24	0.10	2.40	3100	M	31.50	0.10	32	3	B
DC0801524L2B	80	15	24	0.05	1.20	2700	L	27.50	0.09	30	3	B
DC0801524J2B	80	15	24	0.03	0.72	2400	J	22.00	0.05	25	3	B

See page 6 for termination configurations and typical ordering configurations

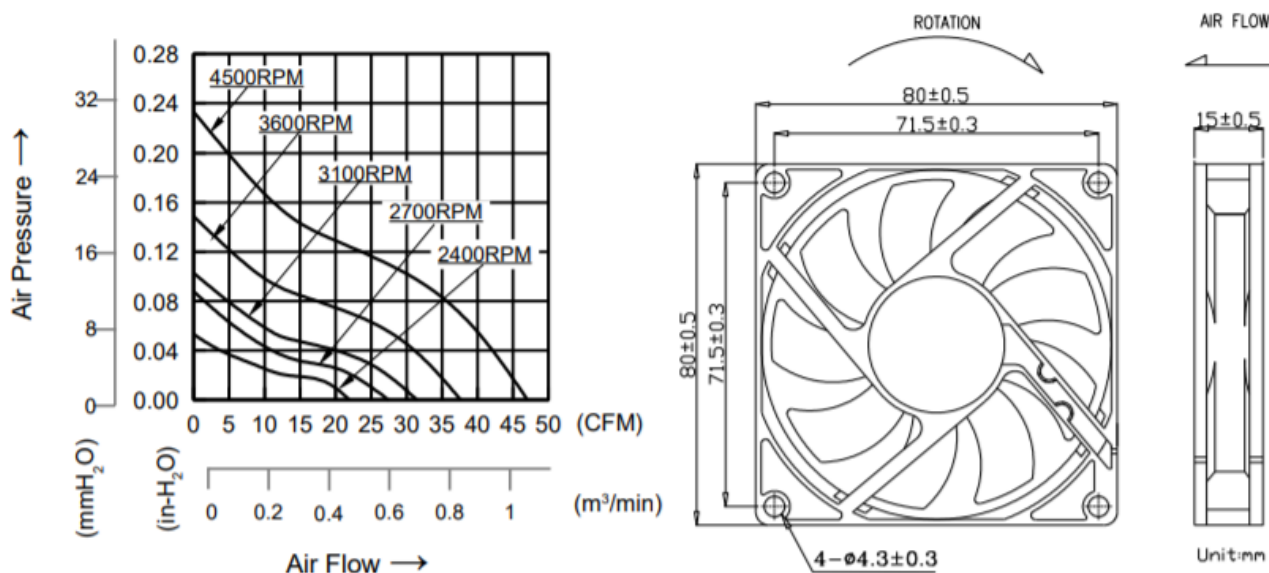

80x80x20mm



- MOTOR : DC single phase brushless motor
- FRAME : PBT (94V-0) ; IMPELLER : PBT(94V-0)
- OPERATING TEMP.: -10°C~70°C
- STORAGE TEMP.: -40°C~70°C
- WEIGHT : 76g
- Dual Ball Bearing
- Lead Length: 300mm +/- 10mm
- 2 Wire: Standard
- 3 Wire: Tach (FG) Optional
- 4 Wire: PWM Optional
- IP Rating: IP55 Optional

Description	Size (mm)	Thickness (mm)	Rated Voltage (VDC)	Rated Current (A)	Rated Power (W)	Rated Speed (RPM)	Speed Code	Max Airflow (CFM)	Max Pressure (InAq)	Noise Level (dB/A)	Tach	PWM
DC0802012U2B	80	20	12	0.30	3.60	4300	U	51.20	0.28	43	3	B
DC0802012H2B	80	20	12	0.24	2.88	3400	H	40.50	0.18	36	3	B
DC0802012M2B	80	20	12	0.18	2.16	3100	M	36.90	0.15	34	3	B
DC0802012L2B	80	20	12	0.16	1.92	2700	L	31.20	0.11	29	3	B
DC0802012J2B	80	20	12	0.13	1.56	2400	J	27.40	0.09	25	3	B
DC0802024U2B	80	20	24	0.14	3.36	4300	U	51.20	0.28	43	3	B
DC0802024H2B	80	20	24	0.09	2.16	3400	H	40.50	0.18	36	3	B
DC0802024M2B	80	20	24	0.08	1.92	3100	M	36.90	0.15	34	3	B
DC0802024L2B	80	20	24	0.07	1.68	2700	L	31.20	0.11	29	3	B
DC0802024J2B	80	20	24	0.04	0.96	2400	J	27.40	0.09	25	3	B

See page 6 for termination configurations and typical ordering configurations

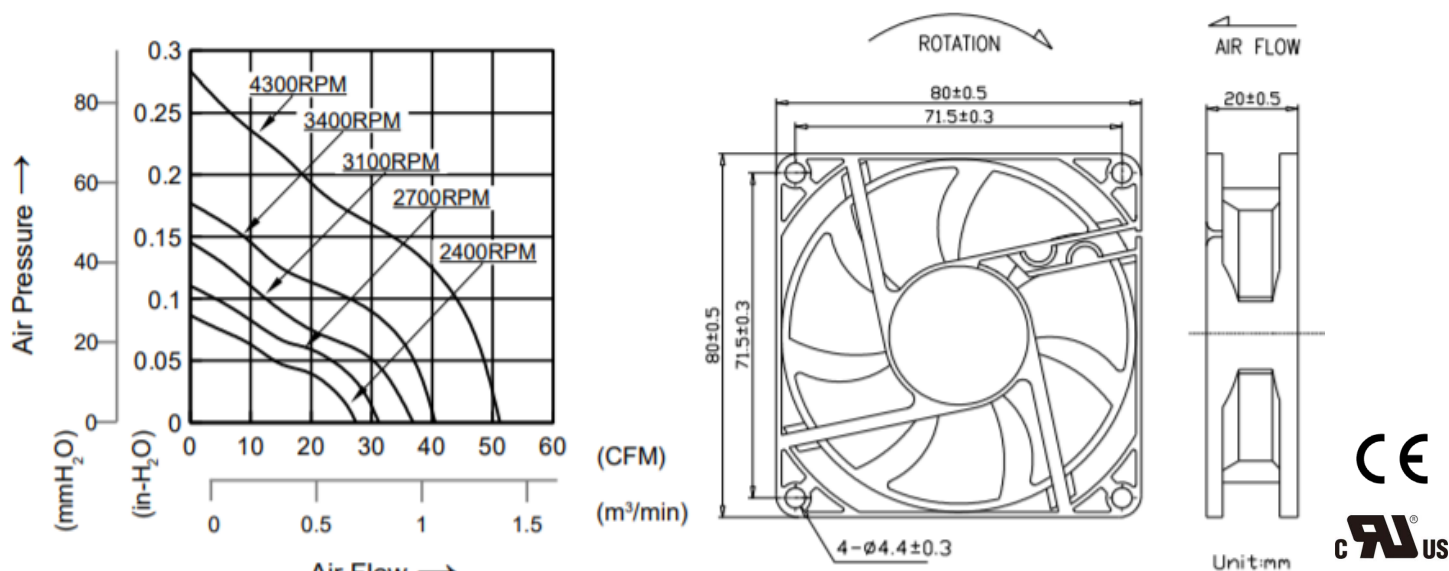

80x80x25mm



- MOTOR : DC single phase brushless motor
- FRAME : PBT (94V-0) ; IMPELLER : PBT(94V-0)
- OPERATING TEMP.: -10°C~70°C
- STORAGE TEMP.: -40°C~70°C
- WEIGHT : 85g
- Dual Ball Bearing
- Lead Length: 300mm +/- 10mm
- 2 Wire: Standard
- 3 Wire: Tach (FG) Optional
- 4 Wire: PWM Optional
- IP Rating: IP55 Optional

Description	Size (mm)	Thickness (mm)	Rated Voltage (VDC)	Rated Current (A)	Rated Power (W)	Rated Speed (RPM)	Speed Code	Max Airflow (CFM)	Max Pressure (InAq)	Noise Level (dB/A)	Tach	PWM
DC0802512U2B	80	25	12	0.73	8.76	6500	U	83.60	0.38	50	3	B
DC0802512H2B	80	25	12	0.48	5.76	5500	H	74.30	0.27	46	3	B
DC0802512M2B	80	25	12	0.25	3.00	5000	M	69.90	0.26	44	3	B
DC0802512L2B	80	25	12	0.20	2.40	4500	L	66.40	0.22	42	3	B
DC0802512I2B	80	25	12	0.13	1.56	4000	I	55.80	0.18	37	3	B
DC0802512J2B	80	25	12	0.15	1.80	3500	J	47.50	0.14	35	3	B
DC0802524H2B	80	25	24	0.30	7.20	5500	H	74.30	0.27	46	3	B
DC0802524M2B	80	25	24	0.26	6.24	5000	M	69.90	0.26	44	3	B
DC0802524L2B	80	25	24	0.23	5.52	4500	L	66.40	0.22	42	3	B
DC0802524I2B	80	25	24	0.12	2.88	4000	I	55.80	0.18	37	3	B
DC0802524J2B	80	25	24	0.10	2.40	3500	J	47.50	0.14	35	3	B
DC0802548M2B	80	25	48	0.18	8.64	5000	M	69.90	0.26	44	3	B
DC0802548L2B	80	25	48	0.16	7.68	4500	L	66.40	0.22	42	3	B
DC0802548I2B	80	25	48	0.15	7.20	4000	I	55.80	0.18	37	3	B
DC0802548J2B	80	25	48	0.12	5.76	3500	J	47.50	0.14	35	3	B

See page 6 for termination configurations and typical ordering configurations

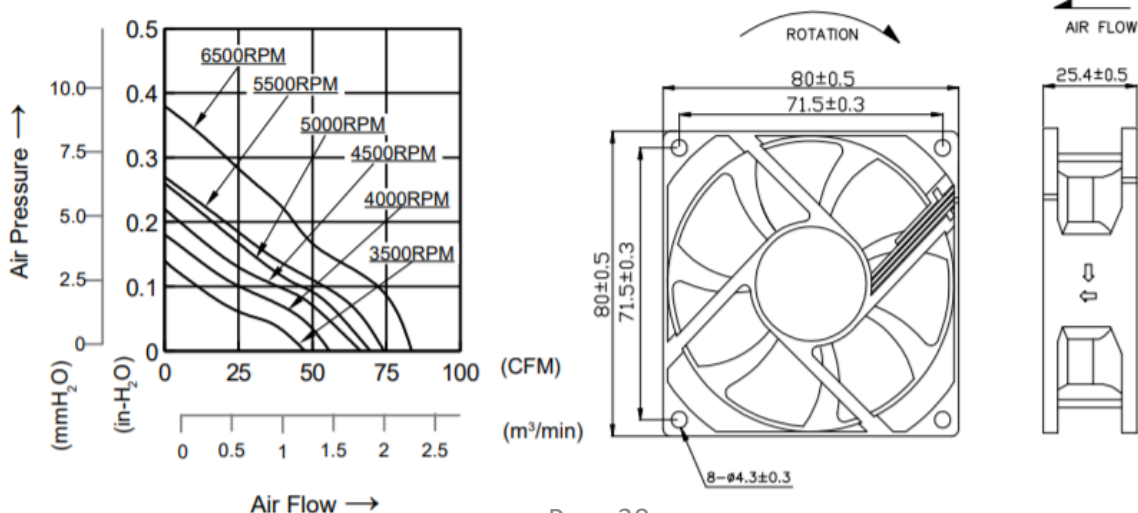

80x80x32mm



- MOTOR : DC single phase brushless motor
- FRAME : PBT (94V-0) ; IMPELLER : PBT(94V-0)
- OPERATING TEMP.: -10°C~70°C
- STORAGE TEMP.: -40°C~70°C
- WEIGHT : 120g
- Dual Ball Bearing
- Lead Length: 300mm +/- 10mm
- 2 Wire: Standard
- 3 Wire: Tach (FG) Optional
- 4 Wire: PWM Optional
- IP Rating: IP55 Optional

Description	Size (mm)	Thickness (mm)	Rated Voltage (VDC)	Rated Current (A)	Rated Power (W)	Rated Speed (RPM)	Speed Code	Max Airflow (CFM)	Max Pressure (InAq)	Noise Level (dB/A)	Tach	PWM
DC0803212U2B	80	32	12	0.95	11.40	6800	U	86.70	0.89	54	3	B
DC0803212H2B	80	32	12	0.50	6.00	5500	H	69.10	0.61	48	3	B
DC0803212M2B	80	32	12	0.35	4.20	4800	M	60.40	0.45	45	3	B
DC0803212L2B	80	32	12	0.20	2.40	4000	L	49.70	0.35	39	3	B
DC0803212J2B	80	32	12	0.15	1.80	3000	J	38.20	0.20	31	3	B
DC0803224U2B	80	32	24	0.37	8.88	6800	U	86.70	0.89	54	3	B
DC0803224H2B	80	32	24	0.25	6.00	5500	H	69.10	0.61	48	3	B
DC0803224M2B	80	32	24	0.17	4.08	4800	M	60.40	0.45	45	3	B
DC0803224L2B	80	32	24	0.15	3.60	4000	L	49.70	0.35	39	3	B
DC0803224J2B	80	32	24	0.06	1.44	3000	J	38.20	0.20	31	3	B

See page 6 for termination configurations and typical ordering configurations

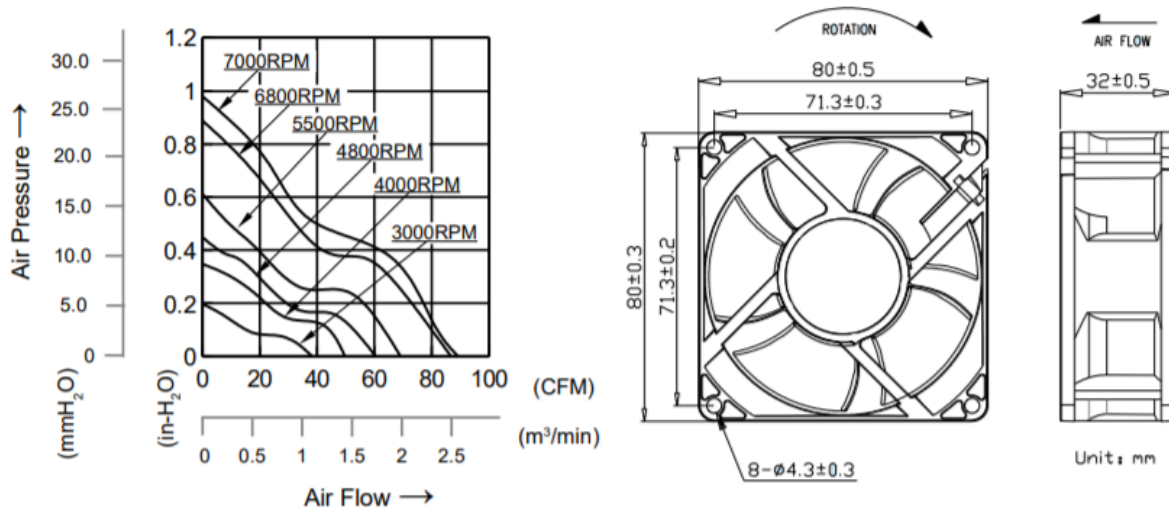

80x80x38mm



- MOTOR : DC single phase brushless motor
- FRAME : PBT (94V-0) ; IMPELLER : PBT(94V-0)
- OPERATING TEMP.: -10°C~70°C
- STORAGE TEMP.: -40°C~70°C
- WEIGHT : 210g
- Dual Ball Bearing
- Lead Length: 300mm +/- 10mm
- 2 Wire: Standard
- 3 Wire: Tach (FG) Optional
- 4 Wire: PWM Optional
- IP Rating: IP55 Optional

Description	Size (mm)	Thickness (mm)	Rated Voltage (VDC)	Rated Current (A)	Rated Power (W)	Rated Speed (RPM)	Speed Code	Max Airflow (CFM)	Max Pressure (InAq)	Noise Level (dB/A)	Tach	PWM
DC0803812V2B	80	38	12	2.70	32.40	9000	V	130.00	2.00	66	3	B
DC0803812U2B	80	38	12	1.50	18.00	7500	U	105.50	1.36	62	3	B
DC0803812H2B	80	38	12	1.00	12.00	6100	H	84.80	0.89	56	3	B
DC0803812M2B	80	38	12	0.76	9.12	5600	M	78.80	0.76	53	3	B
DC0803812L2B	80	38	12	0.40	4.80	4200	L	58.20	0.41	45	3	B
DC0803824V2B	80	38	24	1.46	35.04	9000	V	130.00	2.00	66	3	B
DC0803824U2B	80	38	24	0.86	20.64	7500	U	105.50	1.36	62	3	B
DC0803824H2B	80	38	24	0.45	10.80	6100	H	84.80	0.89	56	3	B
DC0803824M2B	80	38	24	0.38	9.12	5600	M	78.80	0.76	53	3	B
DC0803824L2B	80	38	24	0.16	3.84	4200	L	58.20	0.41	45	3	B
DC0803848V2B	80	38	48	0.63	30.24	9000	V	130.00	2.00	66	3	B
DC0803848U2B	80	38	48	0.45	21.60	7500	U	105.50	1.36	62	3	B
DC0803848H2B	80	38	48	0.21	10.08	6100	H	84.80	0.89	56	3	B
DC0803848M2B	80	38	48	0.19	9.12	5600	M	78.80	0.76	53	3	B
DC0803848L2B	80	38	48	0.15	7.20	4200	L	58.20	0.41	45	3	B

See page 6 for termination configurations and typical ordering configurations

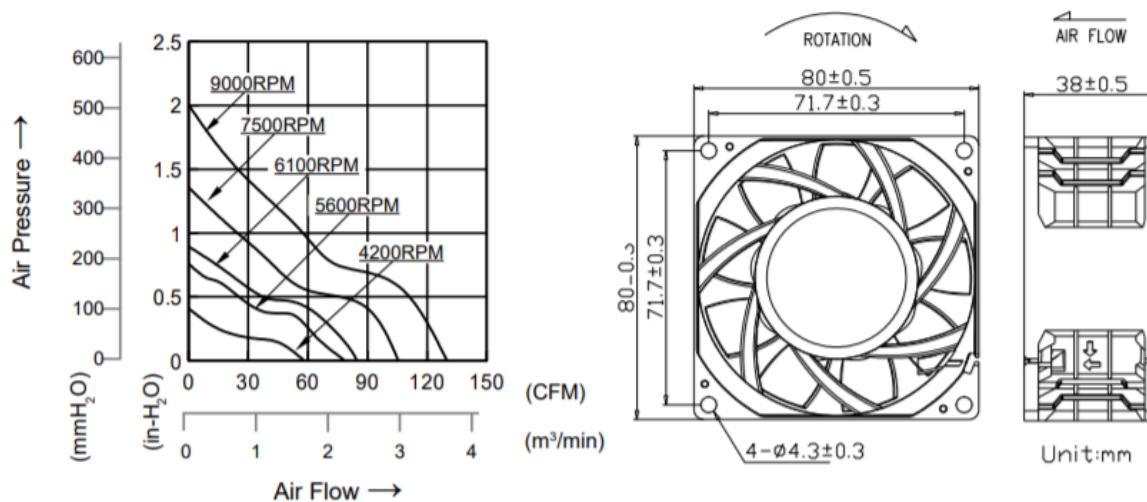

92x92x25mm



- MOTOR : DC single phase brushless motor
- FRAME : PBT (94V-0) ; IMPELLER : PBT(94V-0)
- OPERATING TEMP.: -10°C~70°C
- STORAGE TEMP.: -40°C~70°C
- WEIGHT : 85g
- Dual Ball Bearing
- Lead Length: 300mm +/- 10mm
- 2 Wire: Standard
- 3 Wire: Tach (FG) Optional
- 4 Wire: PWM Optional
- IP Rating: IP55 Optional

Description	Size (mm)	Thickness (mm)	Rated Voltage (VDC)	Rated Current (A)	Rated Power (W)	Rated Speed (RPM)	Speed Code	Max Airflow (CFM)	Max Pressure (InAq)	Noise Level (dB/A)	Tach	PWM
DC0922512V2B	92	25	12	0.43	5.16	4500	V	81.00	0.40	49	3	B
DC0922512U2B	92	25	12	0.30	3.60	3800	U	69.20	0.28	45	3	B
DC0922512H2B	92	25	12	0.20	2.40	3200	H	58.30	0.22	38	3	B
DC0922512M2B	92	25	12	0.14	1.68	2850	M	52.10	0.17	34	3	B
DC0922512L2B	92	25	12	0.11	1.32	2450	L	44.80	0.12	30	3	B
DC0922512J2B	92	25	12	0.09	1.08	2100	J	39.20	0.09	25	3	B
DC0922524V2B	92	25	24	0.25	6.00	4500	V	81.00	0.40	49	3	B
DC0922524U2B	92	25	24	0.19	4.56	3800	U	69.20	0.28	45	3	B
DC0922524H2B	92	25	24	0.14	3.36	3200	H	58.30	0.22	38	3	B
DC0922524M2B	92	25	24	0.08	1.92	2850	M	52.10	0.17	34	3	B
DC0922524L2B	92	25	24	0.07	1.68	2450	L	44.80	0.12	30	3	B
DC0922524J2B	92	25	24	0.05	1.20	2100	J	39.20	0.09	25	3	B
DC0922548V2B	92	25	48	0.15	7.20	4500	V	81.00	0.40	49	3	B
DC0922548U2B	92	25	48	0.14	6.72	3800	U	69.20	0.28	45	3	B
DC0922548H2B	92	25	48	0.12	5.76	3200	H	58.30	0.22	38	3	B
DC0922548M2B	92	25	48	0.08	3.84	2850	M	52.10	0.17	34	3	B
DC0922548L2B	92	25	48	0.06	2.88	2450	L	44.80	0.12	30	3	B
DC0922548J2B	92	25	48	0.05	2.40	2100	J	39.20	0.09	25	3	B

See page 6 for termination configurations and typical ordering configurations

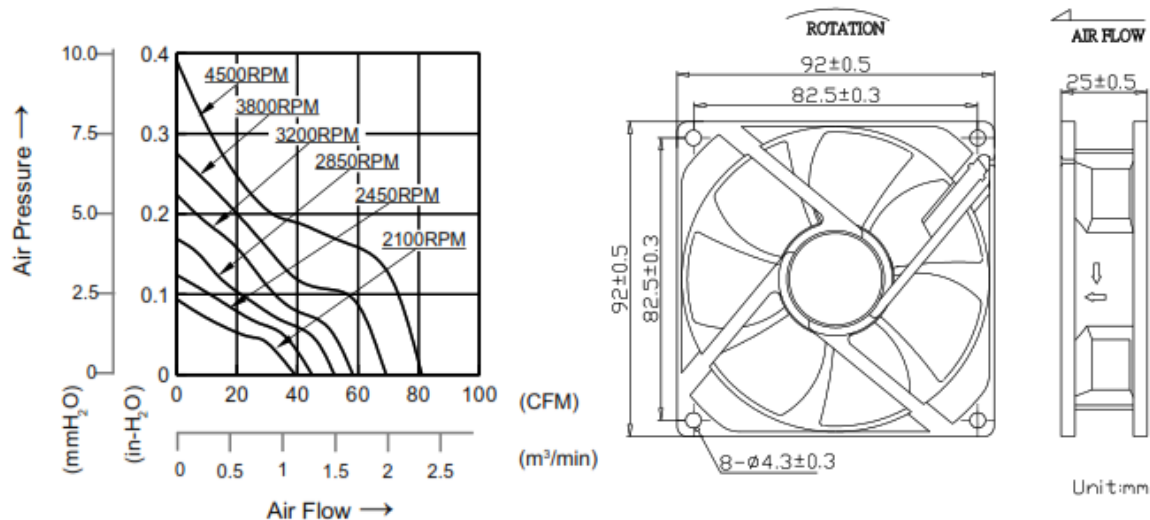

92x92x38mm



- MOTOR : DC single phase brushless motor
- FRAME : PBT (94V-0) ; IMPELLER : PBT(94V-0)
- OPERATING TEMP.: -10°C~70°C
- STORAGE TEMP.: -40°C~70°C
- WEIGHT : 200g
- Dual Ball Bearing
- Lead Length: 300mm +/- 10mm
- 2 Wire: Standard
- 3 Wire: Tach (FG) Optional
- 4 Wire: PWM Optional
- IP Rating: IP55 Optional

Description	Size (mm)	Thickness (mm)	Rated Voltage (VDC)	Rated Current (A)	Rated Power (W)	Rated Speed (RPM)	Speed Code	Max Airflow (CFM)	Max Pressure (InAq)	Noise Level (dB/A)	Tach	PWM
DC0923812V2B	92	38	12	2.95	35.40	8000	V	166.40	1.91	72	3	B
DC0923812U2B	92	38	12	2.50	30.00	7000	U	145.60	1.46	67	3	B
DC0923812H2B	92	38	12	1.20	14.40	6000	H	123.40	1.12	64	3	B
DC0923812M2B	92	38	12	0.90	10.80	5000	M	109.20	0.86	58	3	B
DC0923812L2B	92	38	12	0.50	6.00	4300	L	97.10	0.70	52	3	B
DC0923824V2B	92	38	24	1.45	34.80	8000	V	166.40	1.91	72	3	B
DC0923824U2B	92	38	24	1.20	28.80	7000	U	145.60	1.46	67	3	B
DC0923824H2B	92	38	24	0.73	17.52	6000	H	123.40	1.12	64	3	B
DC0923824M2B	92	38	24	0.45	10.80	5000	M	109.20	0.86	58	3	B
DC0923824L2B	92	38	24	0.30	7.20	4300	L	97.10	0.70	52	3	B
DC0923848V2B	92	38	48	0.81	38.88	8000	V	166.40	1.91	72	3	B
DC0923848U2B	92	38	48	0.44	21.12	7000	U	145.60	1.46	67	3	B
DC0923848H2B	92	38	48	0.37	17.76	6000	H	123.40	1.12	64	3	B
DC0923848M2B	92	38	48	0.25	12.00	5000	M	109.20	0.86	58	3	B
DC0923848L2B	92	38	48	0.18	8.64	4300	L	97.10	0.70	52	3	B

See page 6 for termination configurations and typical ordering configurations

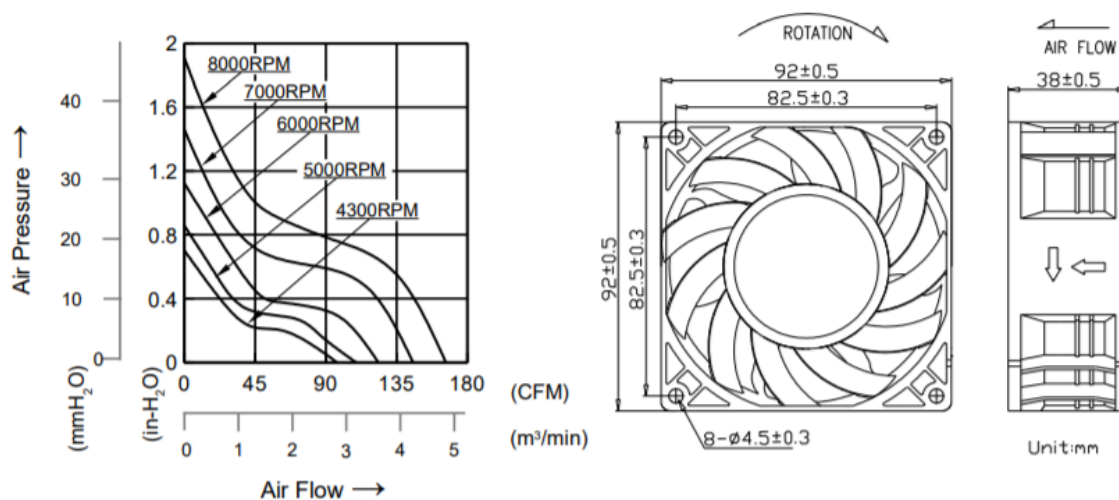

120x120x25mm



- MOTOR : DC single phase brushless motor
- FRAME : PBT (94V-0) ; IMPELLER : PBT(94V-0)
- OPERATING TEMP.: -10°C~70°C
- STORAGE TEMP.: -40°C~70°C
- WEIGHT : 230g
- Dual Ball Bearing
- Lead Length: 300mm +/- 10mm
- 2 Wire: Standard
- 3 Wire: Tach (FG) Optional
- 4 Wire: PWM Optional
- IP Rating: IP55 Optional

Description	Size (mm)	Thickness (mm)	Rated Voltage (VDC)	Rated Current (A)	Rated Power (W)	Rated Speed (RPM)	Speed Code	Max Airflow (CFM)	Max Pressure (InAq)	Noise Level (dB/A)	Tach	PWM
DC1202512V2B	120	25	12	0.65	7.80	4000	V	121.10	0.51	52	3	B
DC1202512U2B	120	25	12	0.62	7.44	3700	U	114.80	0.46	50	3	B
DC1202512H2B	120	25	12	0.50	6.00	3400	H	103.90	0.40	47	3	B
DC1202512M2B	120	25	12	0.48	5.76	2800	M	86.70	0.28	42	3	B
DC1202512L2B	120	25	12	0.30	3.60	2500	L	77.20	0.23	39	3	B
DC1202512J2B	120	25	12	0.20	2.40	2100	J	67.70	0.17	35	3	B
DC1202524V2B	120	25	24	0.36	8.64	4000	V	121.10	0.51	52	3	B
DC1202524U2B	120	25	24	0.28	6.72	3700	U	114.80	0.46	50	3	B
DC1202524H2B	120	25	24	0.22	5.28	3400	H	103.90	0.40	47	3	B
DC1202524M2B	120	25	24	0.15	3.60	2800	M	86.70	0.28	42	3	B
DC1202524L2B	120	25	24	0.13	3.12	2500	L	77.20	0.23	39	3	B
DC1202524J2B	120	25	24	0.10	2.40	2100	J	67.70	0.17	35	3	B
DC1202548V2B	120	25	48	0.20	9.60	4000	V	121.10	0.51	52	3	B
DC1202548U2B	120	25	48	0.18	8.64	3700	U	114.80	0.46	50	3	B
DC1202548H2B	120	25	48	0.16	7.68	3400	H	103.90	0.40	47	3	B
DC1202548M2B	120	25	48	0.12	5.76	2800	M	86.70	0.28	42	3	B
DC1202548L2B	120	25	48	0.10	4.80	2500	L	77.20	0.23	39	3	B
DC1202548J2B	120	25	48	0.08	3.84	2100	J	67.70	0.17	35	3	B

See page 6 for termination configurations and typical ordering configurations

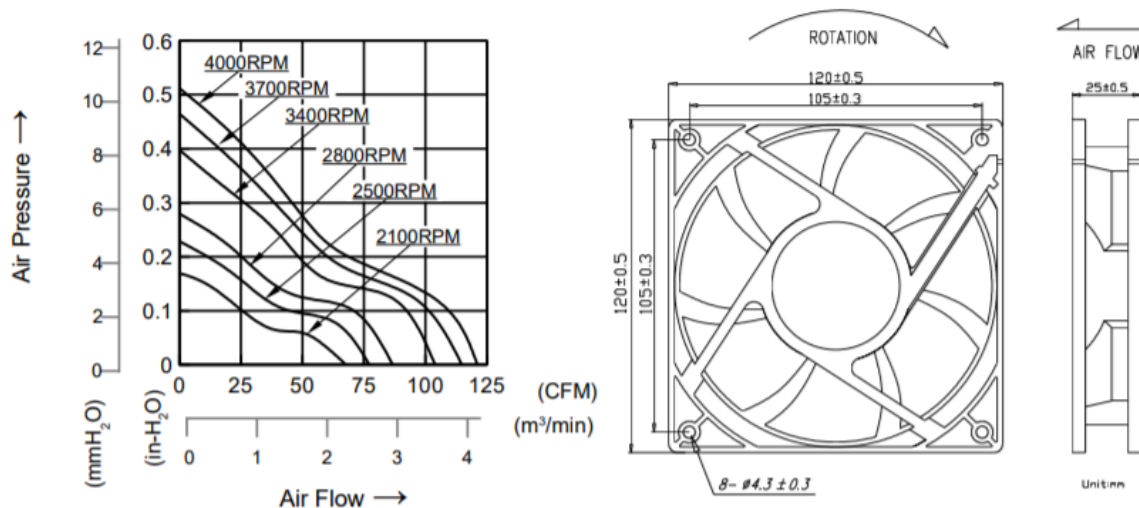

120x120x38mm



- MOTOR : DC single phase brushless motor
- FRAME : PBT (94V-0) ; IMPELLER : PBT(94V-0)
- OPERATING TEMP.: -10°C~70°C
- STORAGE TEMP.: -40°C~70°C
- WEIGHT : 280g
- Dual Ball Bearing
- Lead Length: 300mm +/- 10mm
- 2 Wire: Standard
- 3 Wire: Tach (FG) Optional
- 4 Wire: PWM Optional
- IP Rating: IP55 Optional

Description	Size (mm)	Thickness (mm)	Rated Voltage (VDC)	Rated Current (A)	Rated Power (W)	Rated Speed (RPM)	Speed Code	Max Airflow (CFM)	Max Pressure (InAq)	Noise Level (dB/A)	Tach	PWM
DC1203812W2B	120	38	12	1.90	22.80	4600	W	212.60	0.84	59	3	B
DC1203812V2B	120	38	12	1.60	19.20	4100	V	190.50	0.69	56	3	B
DC1203812U2B	120	38	12	1.55	18.60	4200	U	178.40	0.94	54	3	B
DC1203812H2B	120	38	12	0.80	9.60	3200	H	135.90	0.54	48	3	B
DC1203812M2B	120	38	12	0.60	7.20	2900	M	123.20	0.45	44	3	B
DC1203812L2B	120	38	12	0.40	4.80	2600	L	114.70	0.41	41	3	B
DC1203812J2B	120	38	12	0.35	4.20	2300	J	101.40	0.30	38	3	B
DC1203824W2B	120	38	24	0.75	18.00	4600	W	212.60	0.84	59	3	B
DC1203824V2B	120	38	24	0.62	14.88	4100	V	190.50	0.69	56	3	B
DC1203824U2B	120	38	24	0.66	15.84	4200	U	178.40	0.94	54	3	B
DC1203824H2B	120	38	24	0.52	12.48	3200	H	135.90	0.54	48	3	B
DC1203824M2B	120	38	24	0.31	7.44	2900	M	123.20	0.45	44	3	B
DC1203824L2B	120	38	24	0.19	4.56	2600	L	114.70	0.41	41	3	B
DC1203824J2B	120	38	24	0.15	3.60	2300	J	101.40	0.30	38	3	B
DC1203848W2B	120	38	48	0.45	21.60	4600	W	212.60	0.84	59	3	B
DC1203848V2B	120	38	48	0.32	15.36	4100	V	190.50	0.69	56	3	B
DC1203848U2B	120	38	48	0.44	21.12	4200	U	178.40	0.94	54	3	B
DC1203848H2B	120	38	48	0.23	11.04	3200	H	135.90	0.54	48	3	B
DC1203848M2B	120	38	48	0.21	10.08	2900	M	123.20	0.45	44	3	B
DC1203848L2B	120	38	48	0.15	7.20	2600	L	114.70	0.41	41	3	B
DC1203848J2B	120	38	48	0.12	5.76	2300	J	101.40	0.30	38	3	B

See page 6 for termination configurations and typical ordering configurations



120x120x38mm

