

# THERMAL COMPOUNDS, ADHESIVES & INTERFACE MATERIALS



## DELTABOND™ 156

**DeltaBond™ 156** Thermally Conductive Adhesive is a modified acrylic adhesive designed for permanent mounting on components where heat must be effectively transmitted. Recommended for electromechanical assemblies to bond components and dissipate heat, it replaces mechanical fasteners and compressible pads, silicone grease, and epoxies; eliminates air entrapment, and other variables related to epoxy mixing. This soft paste requires no mixing and flows easily to allow thin bond lines. Primer activated, cure begins upon assembly. DeltaBond™ Activator fixtures at room temperature in less than 5 minutes. Full strength is developed in 4 to 12 hours and fillets become dry to the touch in 24 hours. It is not recommended to use this durable adhesive without the use of DeltaBond™ Activator. **DeltaBond™ 156** is available in kit size; order 156-K (25 ml Syringe and Activator Kit). Shelf life: 1 year.

DELTABOND™ 156		
Characteristics		
Typical Properties Fully Cured	Description	
Test	Results	ASTM
Temperature Range	-65 to 300°F (-54 to 149°C) 300°F to (177°C) Intermittent	
Tensile Strength, at break	2360 psi	D638
Modulus	233,000 psi	D638
Elongation, at break	7.75%	D638
Outgassing	2.5% TLM 0.05% CVCM	E595
Coefficient of Thermal Expansion	7.1 x 10 <sup>-4</sup> (cm/cm°C)	
Tensile Shear	2500psi	D1002
Thermal Conductivity, K (absolute at 86°F (30°C))	3.47 Btu x in./hr ft <sup>2</sup> °F (0.50 W/m °C)	

Note: The absolute thermal conductivity test was developed specifically for measuring thermal properties of thin film adhesive bonds.

DELTABOND™ 156		
Typical Electrical Properties		
Test	Results	ASTM
Dielectric Strength	220 volts/mil	D149
Dielectric Constant, 77°F (25°C)		D150
100 Hz	14.92	
1000 Hz	14.26	
1MM Hz	12.34	
Dissipation Factor, 77°F (25°C)		D150
100 Hz	0.05	
1000 Hz	0.03	
1MM Hz	0.06	
Volume Resistivity	5.2x10 <sup>11</sup> (ohms-cm)	D257
Surface Resistivity	8.6 x 10 <sup>13</sup> (ohms)	D257

Note: DeltaBond™ Thermally Conductive Adhesive-High Strength contains a metallic filler which, in certain applications, may have an effect on electrical properties. Therefore, test each particular application to ensure that electrical properties are as required.

DELTABOND™ 156			
Ordering Guide - Resin and Hardener			
Model Number	Resin		Hardener
	Part No.	Container	Part Number
DeltaBond™ 156	156-K	Resin Kit Hardener Syringe - 0.85 fl oz - 25 ml - 2 oz net/0.44 oz fl contents bottle -12ml	Included in kit hardener with brush applicator - 4.2 oz total wt/kt

### NOTES:

- \* Since the hardener/resin reaction is exothermic, it is important that batch size be matched to hardener speed. Working times given are for approximate batch sizes: A—200 gms, B—200 gms. Larger batch sizes will greatly reduce working time.
  - † After initial cure, material may be handled, removed from fixture, etc., but has not yet achieved full properties and should be room temperature aged or post-cured as shown to achieve full physical and electrical properties.
  - ‡ After initial cure, material may be brought to full physical and electrical properties during post-cure or may be room temperature aged for charted length of time to achieve same full properties.
- The information contained herein is based on data believed to be reliable but we do not assume responsibility for accuracy. All such information is used at the customer's own risk, conditions of use being beyond our control.

## DELTAPADS™ THERMALLY CONDUCTIVE INSULATORS 173 & 174 SERIES

TO-3, TO-66, TO-220, DO-4, DO-5 SHEET

## GREASELESS THERMALLY CONDUCTIVE KAPTON® REINFORCED INSULATORS 175 SERIES



The **173, 174, and 175 Series** are highly efficient thermally conductive insulators designed for semiconductor interface to heat sinks. Their properties eliminate messy concerns associated with thermal greases.

Characteristics	DeltaPads™ 173-7 Series	DeltaPads™ 173-9 Series	DeltaPads™ 174-9 Series	Kapton® 175-6 Series	Test Method
Material Thickness	0.007 in.	0.009 in.	0.009 in.	0.006 in.	Micrometer
Color	Gray	Gray	Tan	Gray	Visual
Tear Strength, lb/in. Typical100	100	100	100	100	ASTM 0624
Volume Resistivity, megohm-cm, Minimum Normal	1.0 x 10 <sup>9</sup>	1.0 x 10 <sup>9</sup>	1.0 x 10 <sup>13</sup>	1 x 10 <sup>13</sup>	ASTM D257
Breakdown Voltage, Minimum	4,000	5,000	5,000	6,000	ASTM 0149
Dielectric Constant at 60 Hz and 100 V Maximum	2.70	2.40	2.50	5.5 @ 1,000 Hz	ASTM D 150
Continuous Use Temperature, °C	-60/+200	-60/+200	-60/+200	-60/+200	-
Thermal Conductivity, cal/cm sec. °C, Minimum	3 x 10 <sup>-3</sup>	3 x 10 <sup>-3</sup>	1 x 10 <sup>-2</sup>	1.2 x 10 <sup>-3</sup>	-
Thermal Resistance (TO-3), 1 in. <sup>2</sup> °C/W	0.33	0.50	0.25	0.40	-
Recommended Mounting Pressure, lb/in. <sup>2</sup>	350/550	350/550	350/550	350/550	Formula*

$$*P \text{ (pressure in psi)} = \frac{T \text{ (torque [in.-lb]} \times N \text{ (number of fasteners)}}{0.2 \times D \text{ (Thread Dia)} \times A \text{ (contact surface area square inches)}}$$

173-7 Series		173-9 Series	174-9 Series	175-6 Series
No Adhesive	Adhesive Backing	No Adhesive	No Adhesive	Greaseless
-	-	173-9-210P	-	175-6-210P
173-7-220P	-	-	-	175-6-220P
173-7-230P	-	173-9-230P	-	175-6-230P
173-7-240P	173-7-240A	173-9-240P	-	175-6-240P
-	-	-	-	175-6-250P
-	-	-	-	175-6-280P
-	-	-	174-9-310P	175-6-310P
-	-	-	-	175-6-320P
-	-	-	-	175-6-330P
-	-	-	-	175-6-410P
-	-	-	-	175-6-610P
173-7-1212P	-	173-9-1212P	174-9-1212P	-

### MECHANICAL DIMENSIONS

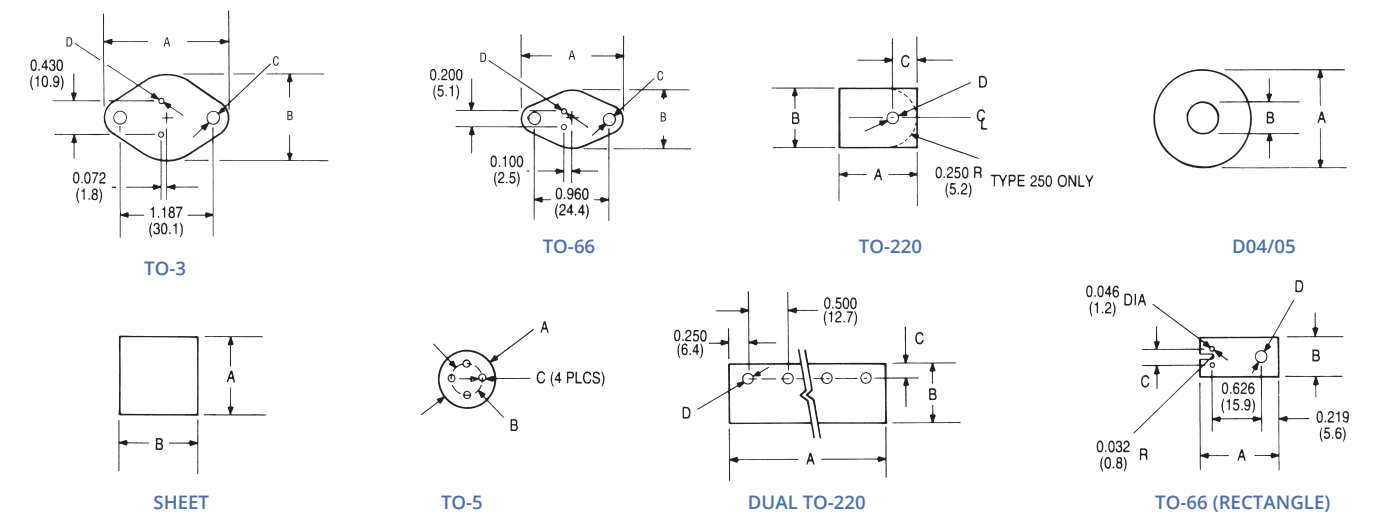

Dimensions: in. (mm)

Contact us: (603) 635-2800