

LIQUID COOLING

<i>Liquid Cold Plates For High-Performance Components & Systems</i>	116-117
<i>Exposed Tube Liquid Cold Plates</i>	118-119
<i>Full Buried Tube Liquid Cold Plates</i>	120-122

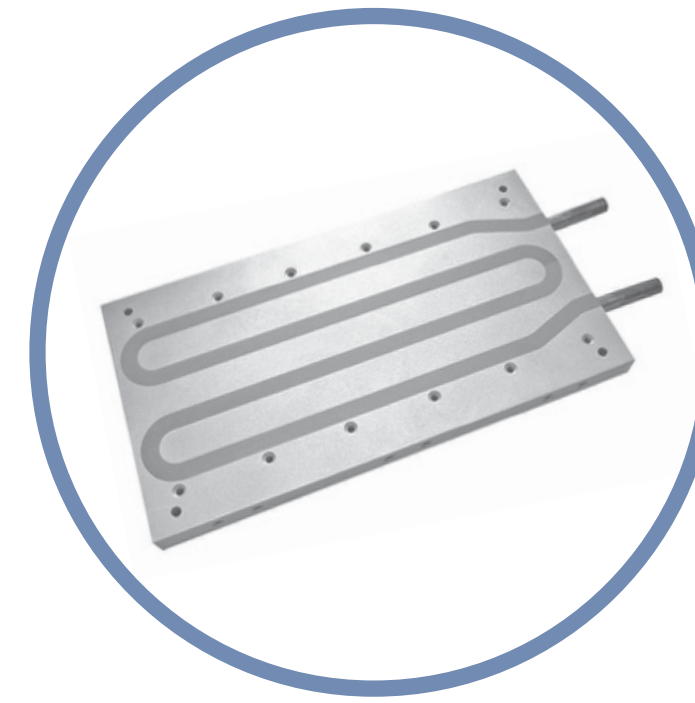

Liquid cooling is a natural evolution beyond air cooling where either due to thermal requirements or footprint requirements, the desired performance can no longer be economically met by air cooling.

There are many ways to accomplish liquid cooling, but the most common method is to have a plate with a flow path that moves liquid under the devices. After the heat is absorbed into the liquid, it is taken out of the plate and into the larger system. While water or water/glycol are the most common fluids used in liquid cooling, gasoline, oil, and refrigerant are other fluids that can be utilized.

There are lots of ways to construct a cold plate and the methods can be driven by the level of performance needed, the materials needed or the environmental requirements.

One construction method is to use a series of cross drilled holes in a plate. The holes intersect in the plate to determine the flow pattern and unneeded patterns are plugged. This construction method can be cost effective, but the pattern is limited to straight lines.

Another method is to embed a tube in a plate by machining a groove in the plate. The tube can either be placed toward the top surface of the plate to provide better cooling to devices mounted on that surface, or it can be embedded further into the plate so that it cools devices mounted on both sides of the plate. This option provides greater flexibility, but the thermal performance is limited because of the surface area of the tube perimeter.

To get more performance, extended surface area in contact with the fluid is required and this leads to machined cold plates. The cold plate is constructed of a plate that has been machined to form some flow passages and then a cover is assembled to capture the flow. The extended surface area can be machined in place or installed by use of a piece of folded fin. The cover can be flat or be another machined plate. The method of assembly of the two parts can be done by gasket/screw, glue/screw, brazing, or welding and is dependent on the required performance and the requirements of the environment.

LIQUID COLD PLATES FOR HIGH-PERFORMANCE COMPONENTS & SYSTEMS

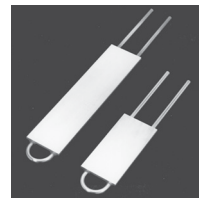

180-10 & 180-11 SERIES

LIQUID COLD PLATES FOR RECTIFIERS AND POWER DIODES

General Purpose

Standard P/N	Cold Plate Body Nominal Dimensions				Overall Length in. (mm)	Overall Thermal Resistance (Plate to Inlet Water)	Weight lbs. (grams)
	Length "A" in. (mm)	Width in. (mm)	Thickness in. (mm)	Channel Width in. (mm)			
180-10-6C	6.000 (152.4)	3.000 (76.2)	0.625 (15.9)	1.250 (31.8)	13.406 (340.5)	0.084°C/W @ 1.5 GPM	0.850 (385.56)
180-10-12C	12.000 (304.8)	3.000 (76.2)	0.625 (15.9)	1.250 (31.8)	19.406 (429.9)	0.041°C/W @ 1.5 GPM	1.700 (771.12)
180-10-24C	24.000 (609.6)	3.000 (76.2)	0.625 (15.9)	1.250 (31.8)	31.406 (797.7)	0.020°C/W @ 1.5 GPM	2.900 (1315.4)
180-11-6C	6.000 (152.4)	5.000 (127.2)	0.688 (17.5)	1.813 (46.1)	13.688 (347.7)	0.084°C/W @ 1.5 GPM	1.500 (680.40)
180-11-12C	12.000 (304.8)	5.000 (127.2)	0.688 (17.5)	1.813 (46.1)	19.688 (500.1)	0.041°C/W @ 1.5 GPM	2.867 (1300.47)
180-11-24C	24.000 (609.6)	5.000 (127.2)	0.688 (17.5)	1.813 (46.1)	31.688 (804.9)	0.020°C/W @ 1.5 GPM	5.730 (2599.13)

Material: Aluminum, no finish. Tubing: Copper (stainless steel tubing available on special order).

LOCAL THERMAL RESISTANCE PER DEVICE PLATE TO INLET WATER (°C/WATT)

℄ to ℄ Device Spacing Inches	Flow - GPM				
	½	1	2	3	4
1.0 (25.4)	0.59	0.52	0.48	0.47	0.46
2.0 (50.8)	0.40	0.36	0.33	0.32	0.31
3.0 (76.2)	0.29	0.26	0.24	0.23	0.22

PERFORMANCE CHARACTERISTICS

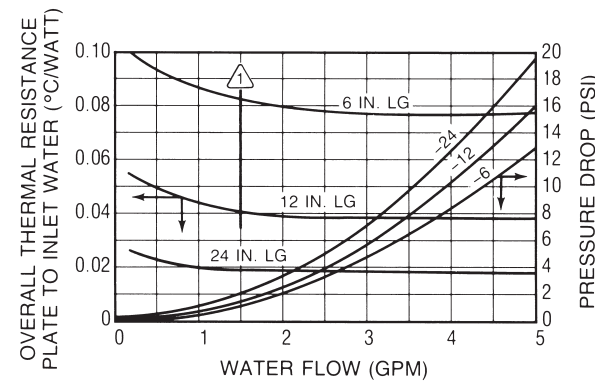

MECHANICAL DIMENSIONS

180-10 SERIES

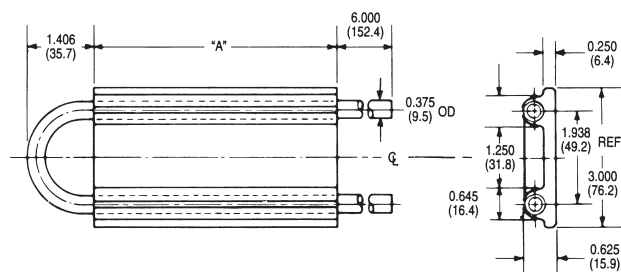

180-11 SERIES

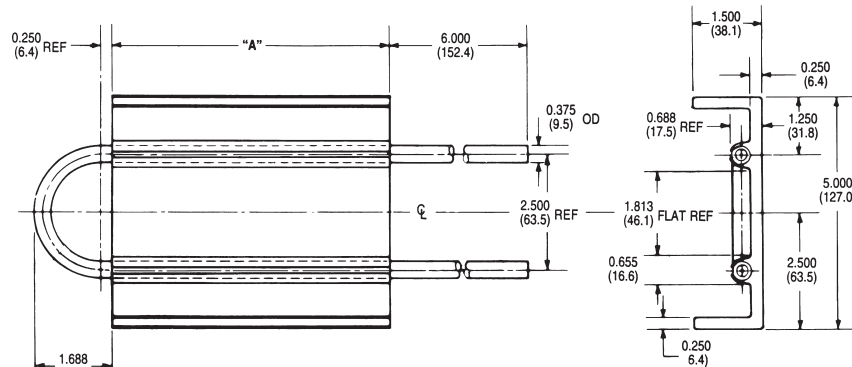

Dimensions: in. (mm)

wakefield-vette.com

Standard P/N	Length "A" in. (mm)
180-10-6C	6.000 in. (152.4)
180-10-12C	12.000 in. (304.8)
180-10-24C	24.000 in. (609.6)
180-11-6C	6.000 in. (152.4)
180-11-12C	12.000 in. (304.8)
180-11-24C	24.000 in. (609.6)

LIQUID COLD PLATES FOR RECTIFIERS, DIODES, AND POWER MODULES

General Purpose

180-12 & 180-20 SERIES

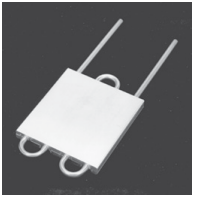

Standard P/N	Cold Plate Body Nominal Dimensions			Mounting Surfaces	Overall Length in. (mm)	Overall Thermal Resistance (Plate to Inlet Water)	Weight lbs. (grams)
	Length "A" in. (mm)	Width in. (mm)	Thickness in. (mm)				
180-12-6C	6.000 (152.4)	7.750 (196.9)	0.658 (16.7)	Single	13.406 (340.5)	0.038°C/W @ 1.0 GPM	2.270 (1029.67)
180-12-12C	12.000 (304.8)	7.750 (196.9)	0.658 (16.7)	Single	19.406 (429.9)	0.018°C/W @ 1.0 GPM	4.300 (1950.48)
180-12-24C	24.000 (609.6)	7.750 (196.9)	0.658 (16.7)	Single	31.406 (797.7)	0.009°C/W @ 1.0 GPM	8.600 (3900.96)
180-20-6C	6.000 (152.4)	5.500 (139.7)	0.690 (17.5)	Double	13.125 (333.4)	0.038°C/W @ 1.0 GPM	1.090 (494.42)

LOCAL THERMAL RESISTANCE PER DEVICE PLATE TO INLET WATER (°C/WATT)

℄ to ℄ Device Spacing Inches	Flow - GPM				
	½	1	2	3	4
1.0 (25.4)	0.76	0.67	0.62	0.59	0.57
2.0 (50.8)	0.58	0.49	0.43	0.40	0.39
3.0 (76.2)	0.42	0.34	0.30	0.28	0.27

MECHANICAL DIMENSIONS

180-12 SERIES

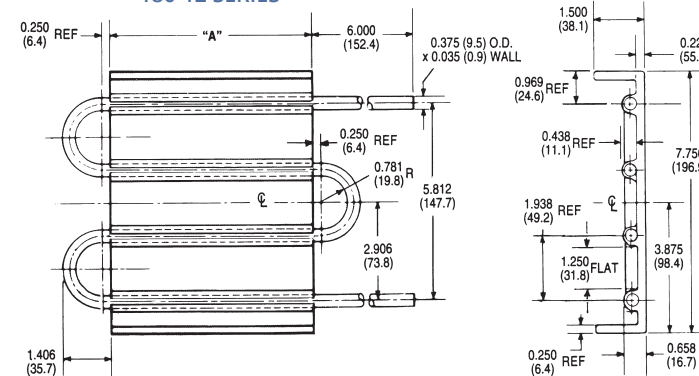

180-20 SERIES

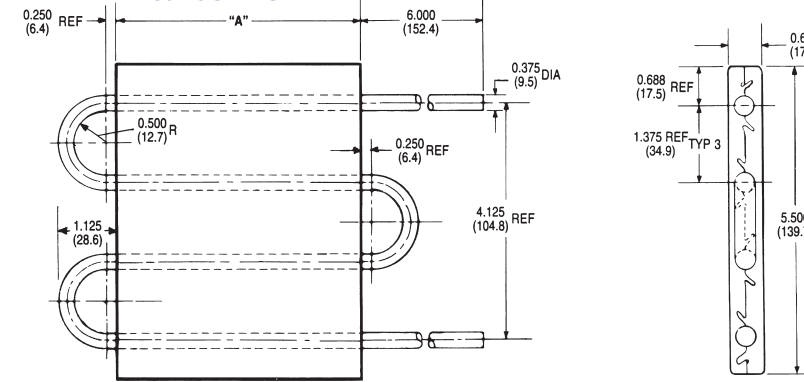

Dimensions: in. (mm)

Contact us: (603) 635-2800

PERFORMANCE CHARACTERISTICS

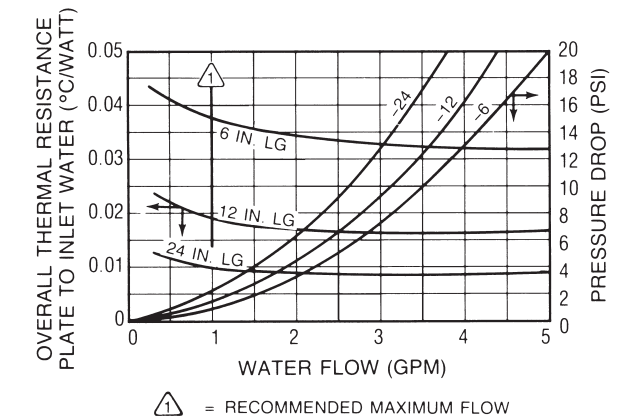

Standard P/N	Length "A" in. (mm)
180-12-6C	6.000 in. (152.4)
180-12-12C	12.000 in. (304.8)
180-12-24C	24.000 in. (609.6)
180-20-6C	6.000 in. (152.4)

EXPOSED TUBE LIQUID COLD PLATES

Wakefield-Vette's exposed tube liquid cold plates ensure minimum thermal resistance between the power device and the cold plate by placing the coolant tube in direct contact with the power device's base. Direct contact reduces the number of thermal interfaces between device and fluid thus increasing performance for the application.

Part Number	Description	"X" Dimension Inches	Passes	Figure
120455	Exposed Tube 2- Pass Cold plate	N/A	2	1
120456	Exposed Tube 4- Pass Cold plate	6.00	4	2
120457	Exposed Tube 4- Pass Cold plate	12.00	4	2
120458	Exposed Tube 6- Pass Cold plate	6.00	6	3
120459	Exposed Tube 6- Pass Cold plate	12.00	6	3
120460	Exposed Tube 6- Pass Cold plate	24.00	6	3

KEY SPECIFICATIONS	
• Base Plate: Extruded Aluminum.	
• Copper Tube Material: 0.375" OD x .049" wall.	
• Thermal Epoxy fill with high thermal conductivity.	

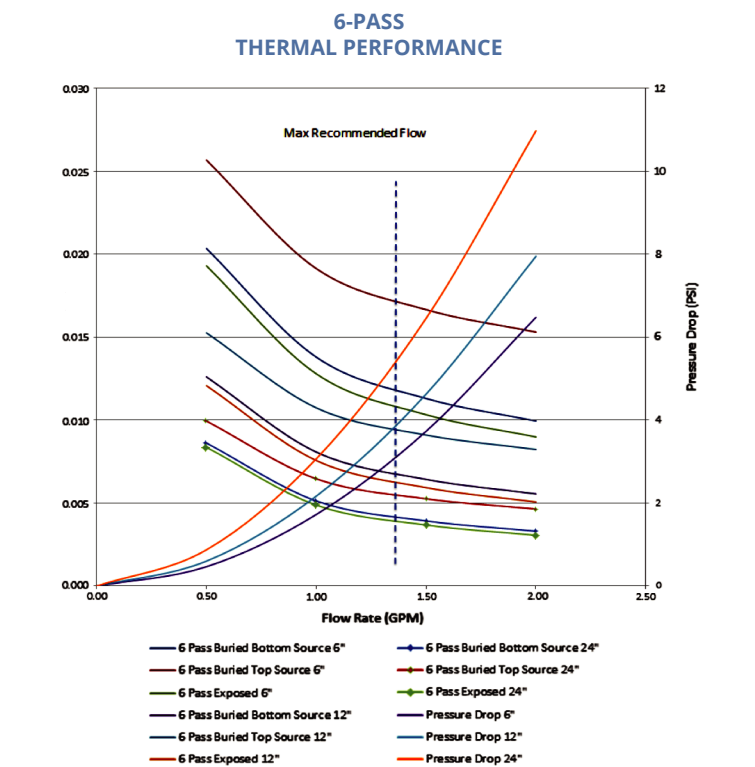
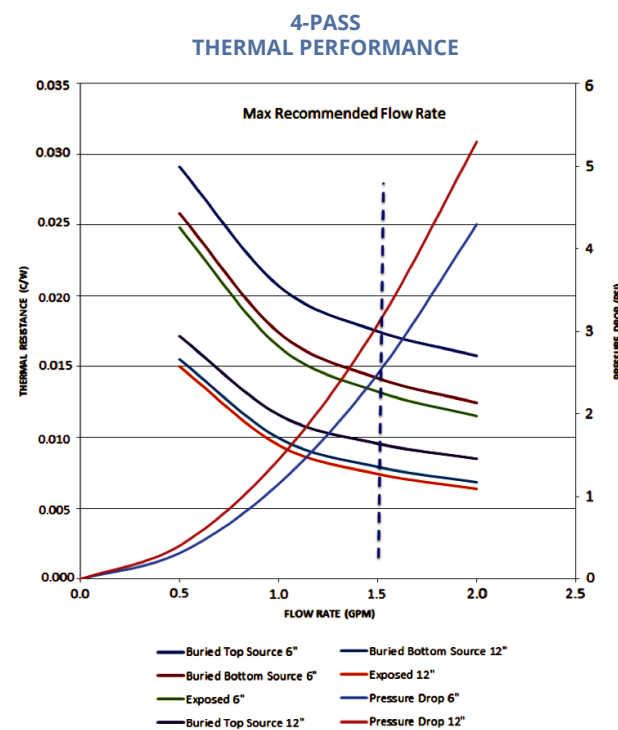
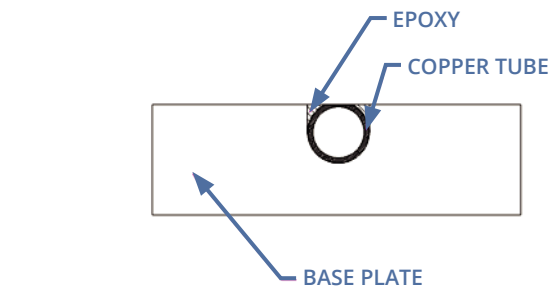
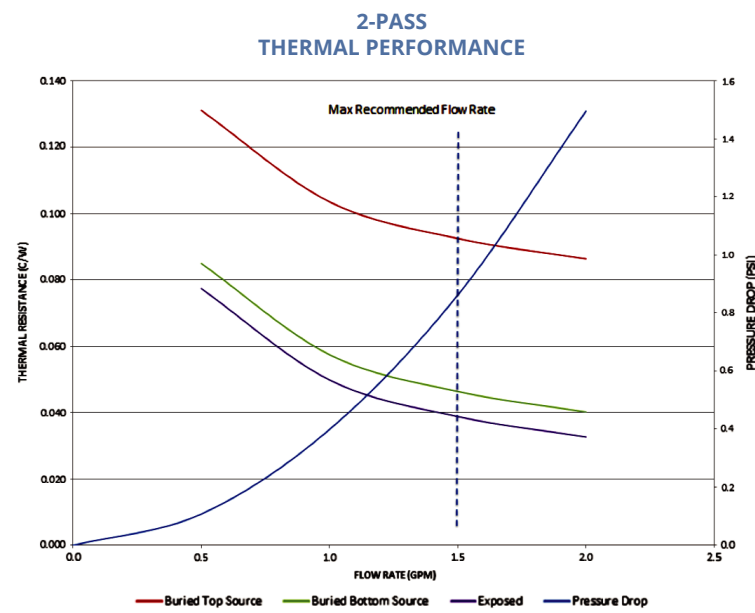

Custom Exposed Tube Liquid Cold Plates Available

Contact Wakefield-Vette for more information or visit www.wakefield-vette.com



PART NUMBER 120455

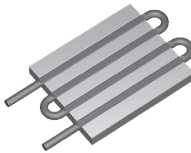
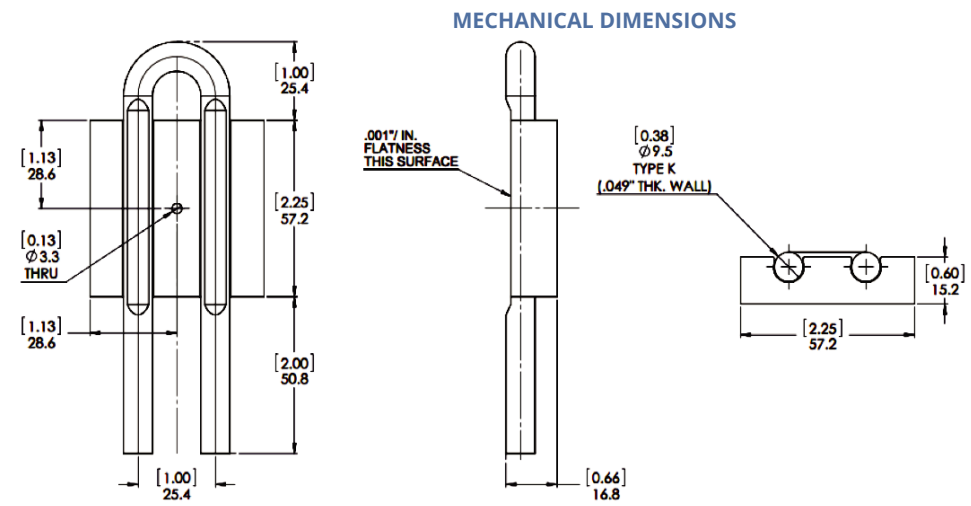
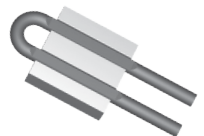

PART NUMBER 120456 & 120457

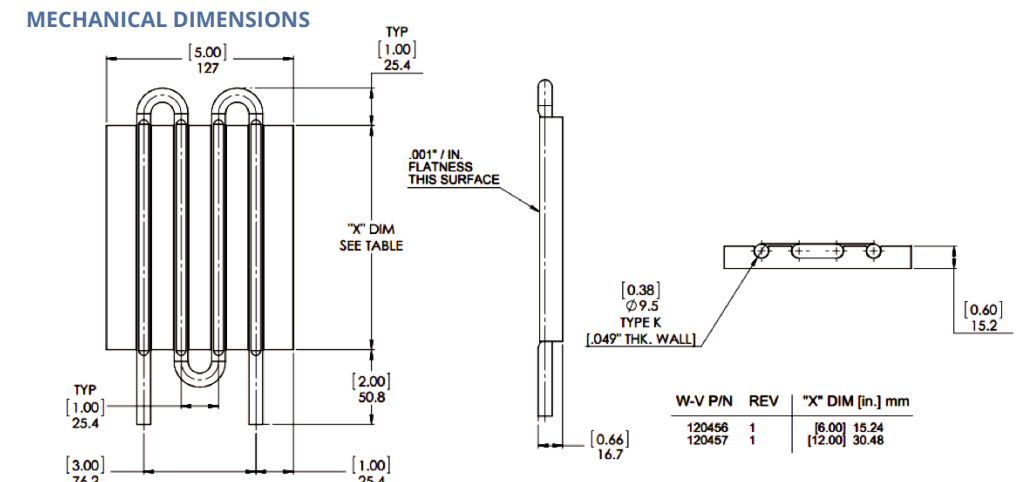

PART NUMBER 120458, 120459, & 120460

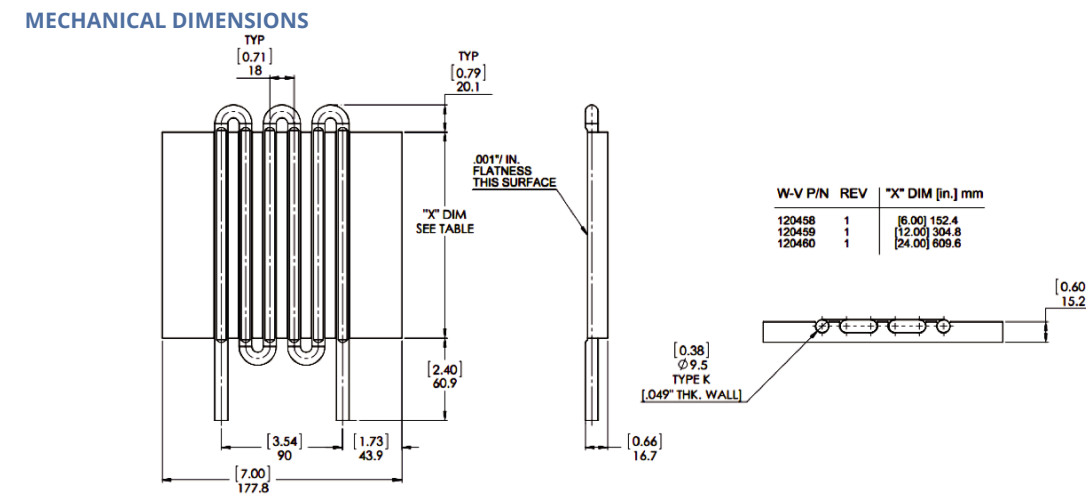
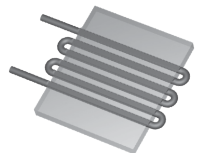

FULL BURIED TUBE LIQUID COLD PLATES

Wakefield-Vette's fully buried tube liquid cold plates have the ability to cool both sides of the cold plate because of it's positioning within the base plate. Another key feature of the fully buried tube is that it is not exposed to the outside environment. Some engineers prefer the epoxy layer above the tube to protect the tube from leakage.

Part Number	Description	"X" Dimension Inches	Passes	Figure
120959	Fully Buried Tube 2- Pass Cold plate	N/A	2	1
120960	Fully Buried Tube 4- Pass Cold plate	6.00	4	2
120961	Fully Buried Tube 4- Pass Cold plate	12.00	4	2
120962	Fully Buried Tube 6- Pass Cold plate	6.00	6	3
120963	Fully Buried Tube 6- Pass Cold plate	12.00	6	4
120964	Fully Buried Tube 6- Pass Cold plate	24.00	6	5

KEY SPECIFICATIONS

- Base Plate: Extruded Aluminum.
- Copper Tube Material: 0.375" OD x .049" wall.
- Thermal Epoxy fill with high thermal conductivity.

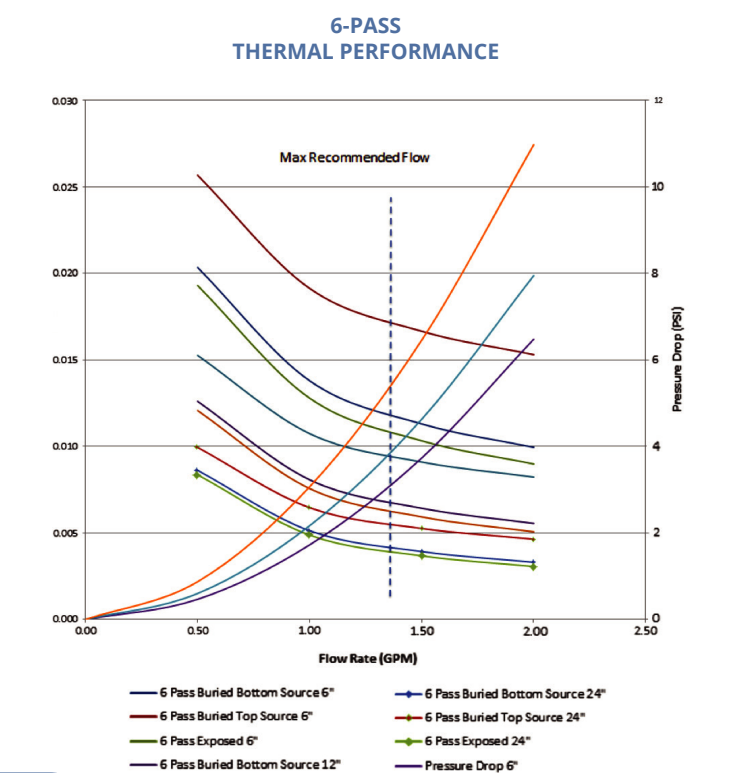
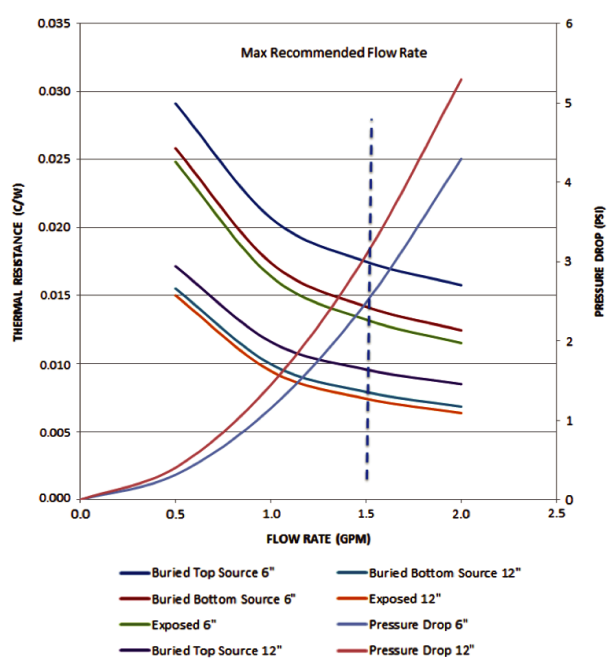
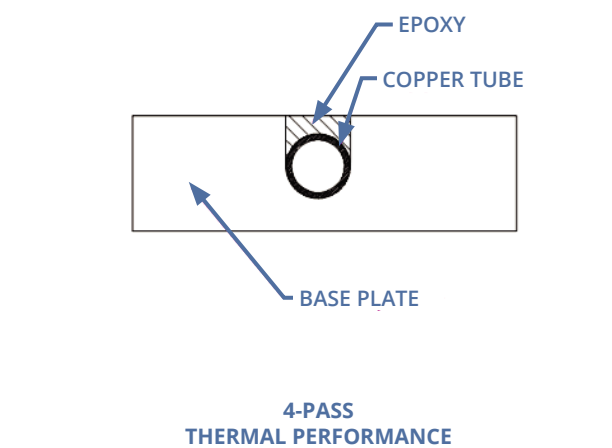
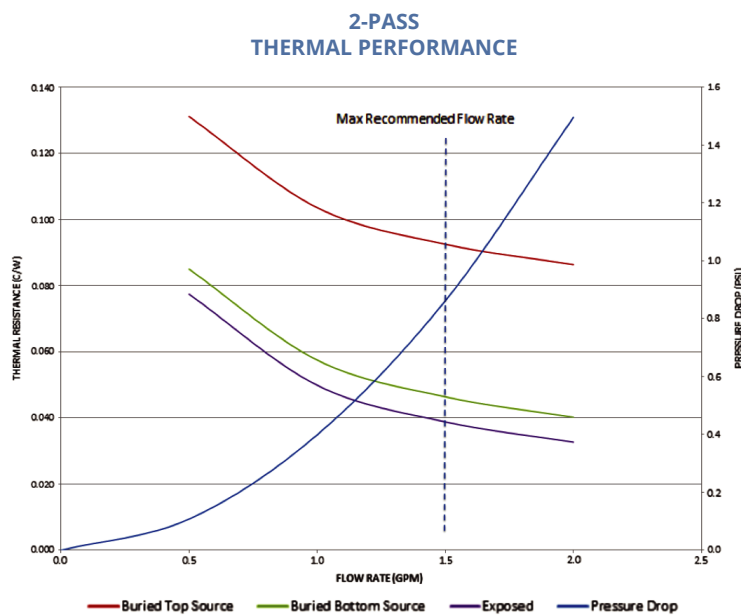

Custom Full Buried Tube Liquid Cold Plates Available
 Contact Wakefield-Vette for more information or visit www.wakefield-vette.com



PART NUMBER 120959

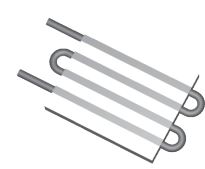
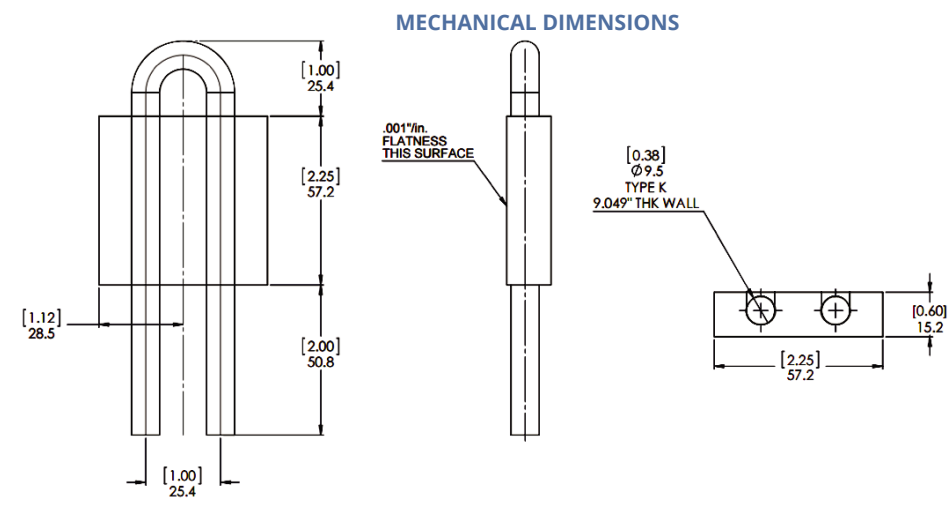
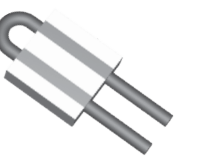

PART NUMBER 120960 & 120961

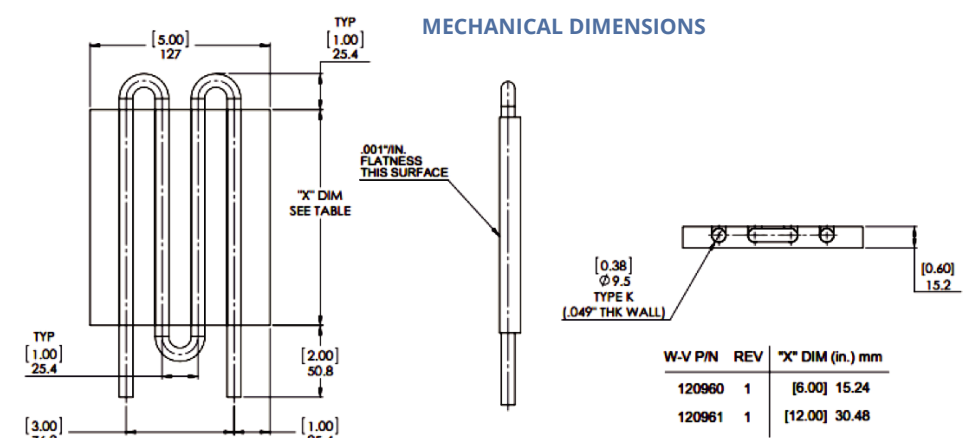

PART NUMBER 12062

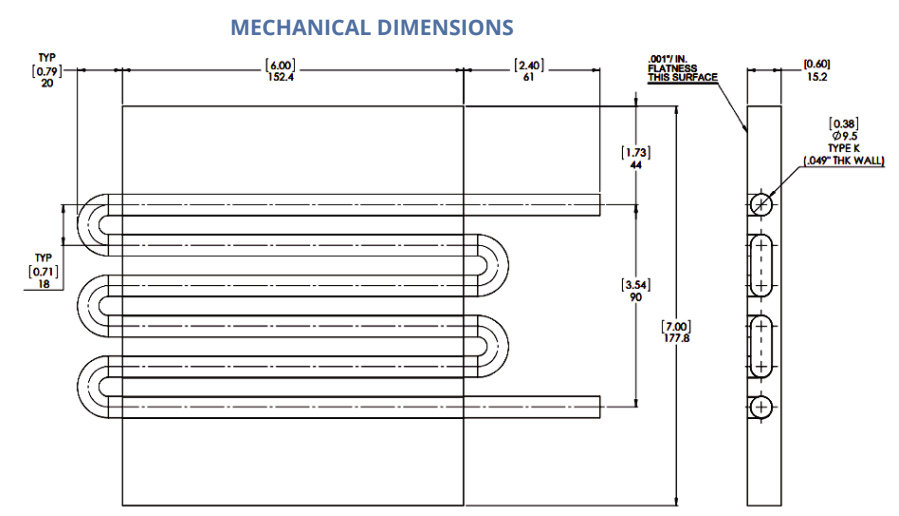
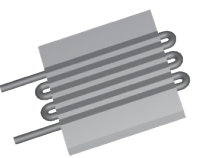

FULL BURIED TUBE LIQUID COLD PLATES

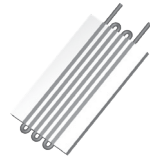

PART NUMBER 120963



MECHANICAL DIMENSIONS

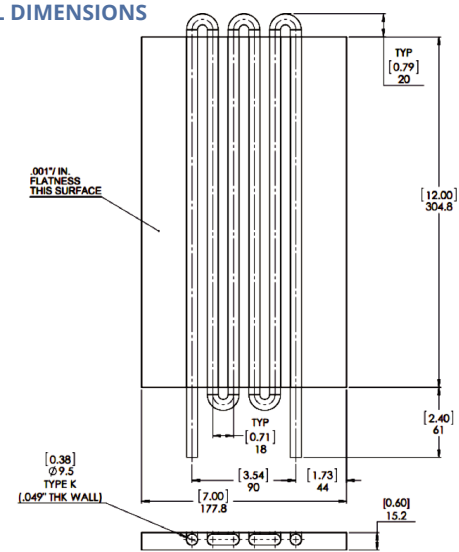

PART NUMBER 120964



MECHANICAL DIMENSIONS

