

# Thermoelectric Assemblies



## TEC Assembly Series

### Air to Air Thermoelectric Cooler Assemblies

Wakefield- Vette's TEC Assembly series of Air to Air Thermoelectric Cooler Assemblies are usually used to cool (or heat) objects in enclosures. Heat is absorbed and dissipated by heat exchangers equipped with fans. To install, simply cut a hole, plug in the assembly and connect it to a power source. Our coolers are compact and dependable. All models are optimized for  $\Delta T$  and efficiency. A variety of voltage options from 12 to 48 volts and cooling capacity from 15 watts to 200 watts are available, Typical applications include cooling electronics cabinets, analytical instruments, commercial refrigeration, food transportation boxes and small electronics enclosures.



WV P/N	Description	Heat Transfer Type	Power Cooling	Current	Voltage	Operation Temperature	Outline (L/W/H)
TEMA-AA-50-12	THERMOELECTRIC ASSY DIRECT-AIR to Air 12V	Air to Air	50W	8.0A	12V	-20 to 60°C	160mm x 122.4mm x 147mm
TEMA-AA-50-24	THERMOELECTRIC ASSY DIRECT-AIR to Air 24V	Air to Air	50W	4.0A	24V	-20 to 60°C	160mm x 122.4mm x 147mm

### Air to Plate Thermoelectric Cooler Assemblies

Wakefield Vette's Air to Plate Cooler Assemblies are typically used in three key applications for cooling/heating:

- Objects directly on the cold plate, or objects on an additional cold plate of your own design
- Enclosures by attaching a thermal conductive container to the cold plate
- Liquids by attaching a thermal conductive tank or liquid heat sink to the cold plate

The heat is absorbed by the cold plate, pumped through the TE modules and then dissipated to the air by an air heat sink. Our coolers deliver compact and reliable cooling in a range from 42 to 80 watts. All models are optimized for a variety of voltages,  $\Delta T$  and efficiency. Typical applications include cooling electronics, analytical instruments, lasers and commercial refrigeration



WV P/N	Description	Heat Transfer Type	Power Cooling	Current	Voltage	Operation Temperature	Outline (L/W/H)
TEMA-AP-40-12	THERMOELECTRIC ASSY DIRECT-AIR to Plate 12V	Air to Plate	40W	3.9A	12V	-20 to 60°C	120mm x 102mm x 80mm
TEMA-AP-80-24	THERMOELECTRIC ASSY DIRECT-AIR 2 Plate 24V	Air to Plate	80W	4.2A	24V	-20 to 60°C	203mm x 155mm x 152mm

# Thermoelectric Assembly Performance Specifications

## Air to Air Thermoelectric Cooler Assembly

### TEMA-AA-50-12

The TEMA-AA-50-12 Thermoelectric air conditioner is designed for electronic cabinets and environmental chambers. It can maintain ambient temperatures while removing up to 50W. This model is powered by 12VDC. The TEMA-AA-50-12 is essentially maintenance-free, with no filters to change, and it can be mounted in any orientation, offering design flexibility with solid-state reliability.

#### Features:

- 50W Capacity at  $DT = 0^{\circ}C$  & Ambient Temperature =  $30^{\circ}C$
- Refrigerant Free – environmentally friendly
- Wide operating temperature range of  $-20^{\circ}C$  to  $+60^{\circ}C$
- Shift between heating and cooling without using a separate heater
- Reduced noise and vibration from solid-state heat pump

#### Applications:

- Outdoor Enclosures
- Outdoor/Indoor Kiosks and Displays
- Food/Consumer Refrigerator
- Battery Cabinet

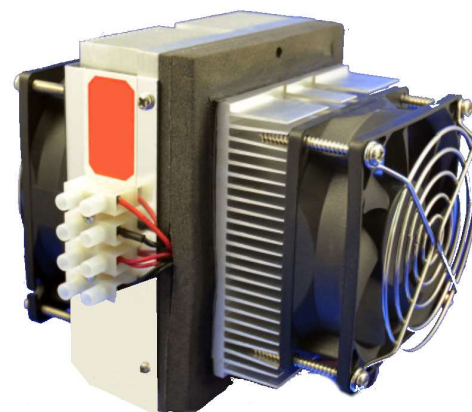

### General Specifications:

P/N	TEMA-AA-50-12
Cooling Method/Radiating Method	Forced Air/Forced Air
Ambient Temperature	-20 to $60^{\circ}C$
Cooling Capacity/Input Power	50W / 95W
Heating Capacity	135W
Fan Current	0.4A (Radiator) / 0.3A (Cooling)
TEC Nominal/Startup Current	8.0A / 9.1A
Nominal/Maximum Voltage	12/15 VDC
Overall Dimension	160mm x 122.4mm x 147mm
Weight	1.8kg (4 lbs)
Lifetime	>70,000 Hours
Cooling Performance Tolerance	10%

**Wakefield-Vette reserves the right to change these specifications without notice**

# Thermoelectric Assembly Performance Specifications

## Air to Air Thermoelectric Cooler Assembly

TEMA-AA-50-12

### Performance Curve:

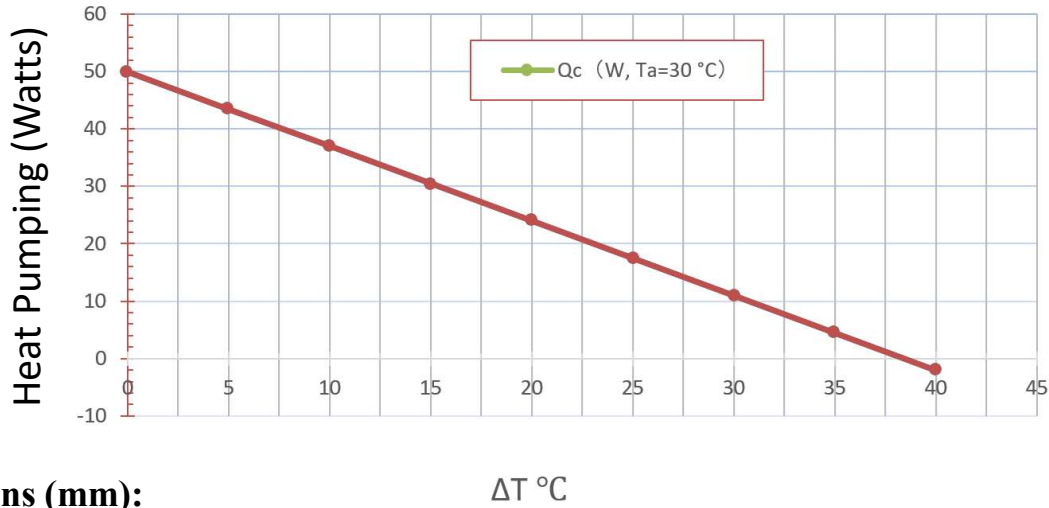

### Dimensions (mm):

$\Delta T$  °C

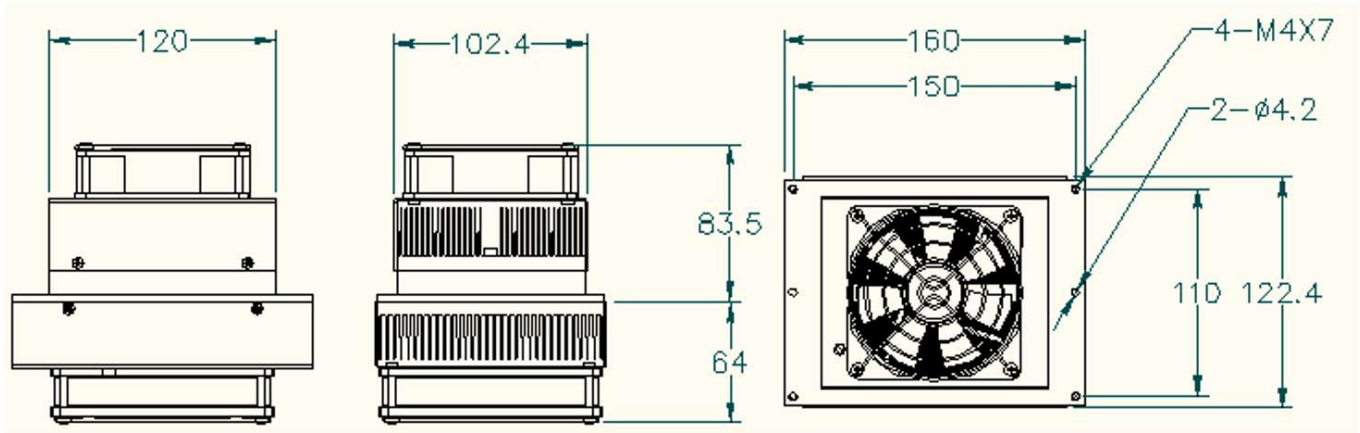

### Installation and Connector (mm):

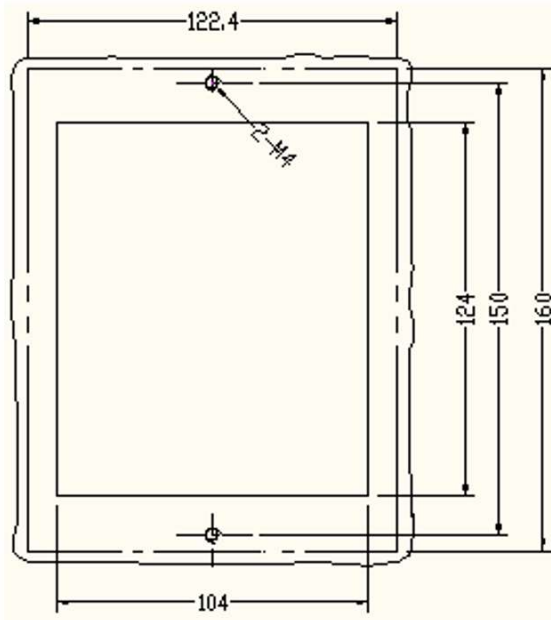

Connector	Wire
1	TEC +
2	TEC -
3	Fan +
4	Fan -



Wakefield-Vette reserves the right to change these specifications without notice

# Thermoelectric Assembly Performance Specifications

## Air to Air Thermoelectric Cooler Assembly

### TEMA-AA-50-24

The TEMA-AA-50-24 Thermoelectric air conditioner is designed for electronic cabinets and environmental chambers. It can maintain ambient temperatures while removing up to 50W. This model is powered by 24VDC. The TEMA-AA-50-24 is essentially maintenance-free, with no filters to change, and it can be mounted in any orientation, offering design flexibility with solid-state reliability.

#### Features:

- 50W Capacity at  $DT = 0^{\circ}C$  & Ambient Temperature =  $30^{\circ}C$
- Refrigerant Free – environmentally friendly
- Wide operating temperature range of  $-20^{\circ}C$  to  $+60^{\circ}C$
- Shift between heating and cooling without using a separate heater
- Reduced noise and vibration from solid-state heat pump

#### Applications:

- Outdoor Enclosures
- Outdoor/Indoor Kiosks and Displays
- Food/Consumer Refrigerator
- Battery Cabinet



### General Specifications:

P/N	TEMA-AA-50-24
Cooling Method/Radiating Method	Forced Air/Forced Air
Ambient Temperature	-20 to $60^{\circ}C$
Cooling Capacity/Input Power	50W / 95W
Heating Capacity	135W
Fan Current	0.25A (Radiator) / 0.18A (Cooling)
TEC Nominal/Startup Current	4.0A / 4.6A
Nominal/Maximum Voltage	24/30 VDC
Overall Dimension	160mm x 122.4mm x 147mm
Weight	1.8kg (4 lbs)
Lifetime	>70,000 Hours
Cooling Performance Tolerance	10%

**Wakefield-Vette reserves the right to change these specifications without notice**

# Thermoelectric Assembly Performance Specifications

## Air to Air Thermoelectric Cooler Assembly

TEMA-AA-50-24

### Performance Curve:

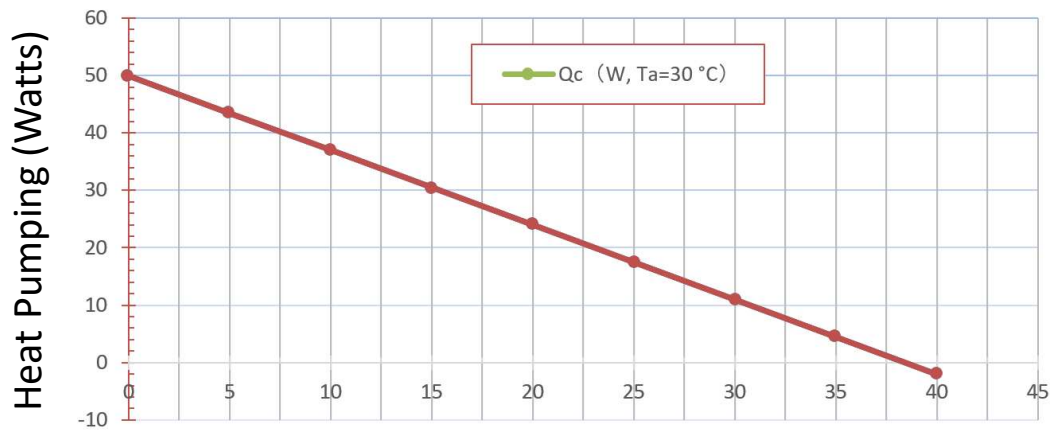

### Dimensions (mm):

$\Delta T$  °C

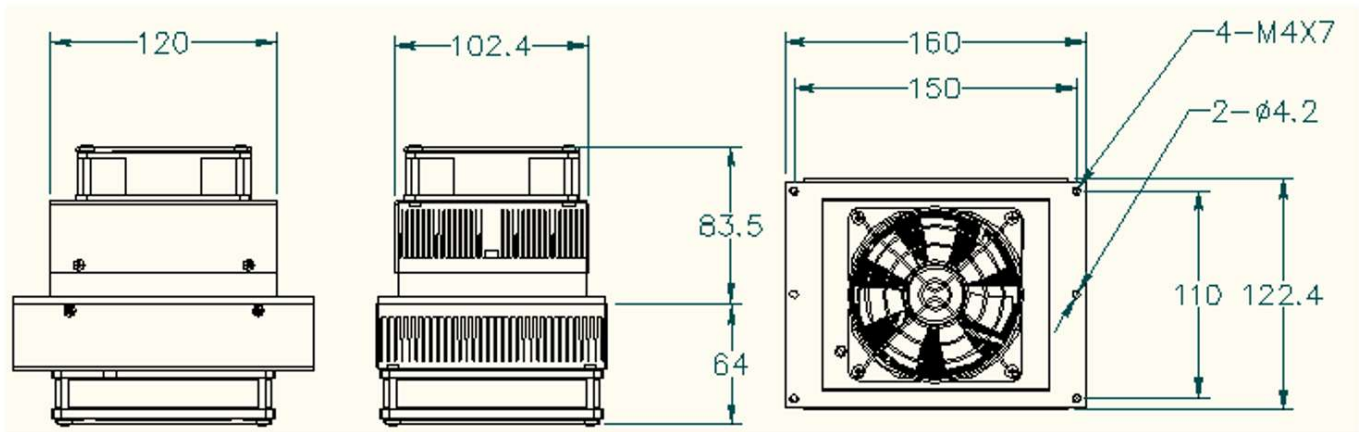

### Installation and Connector (mm):

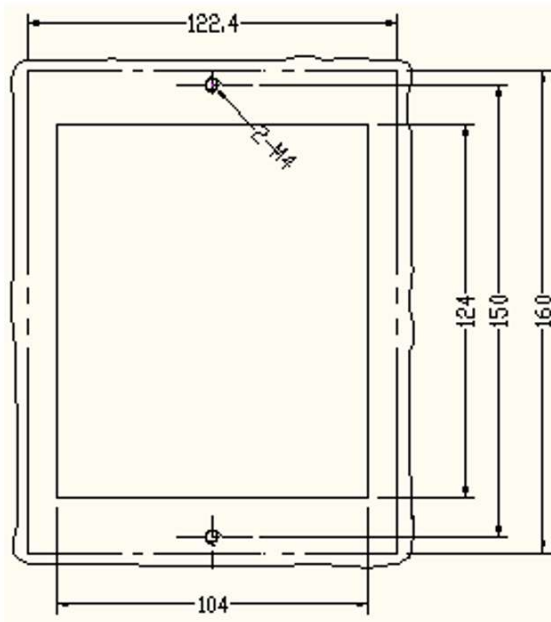

Connector	Wire
1	TEC +
2	TEC -
3	Fan +
4	Fan -



Wakefield-Vette reserves the right to change these specifications without notice

# Thermoelectric Assembly Performance Specifications

## Air to Plate Thermoelectric Cooler Assembly

### TEMA-AP-40-12

The TEMA-AP-40-12 Thermoelectric plate cooler is designed for electronic cabinets and environmental chambers. It can maintain ambient temperatures while removing up to 40W. This model is powered by 12VDC and is essentially maintenance-free, with no filters to change. It can be mounted in any orientation, offering design flexibility with solid-state reliability.

#### Features:

- 40W Capacity at  $DT = 0^{\circ}C$  & Ambient Temperature =  $30^{\circ}C$
- Refrigerant Free – environmentally friendly
- Wide operating temperature range of  $-20^{\circ}C$  to  $+60^{\circ}C$
- Shift between heating and cooling without using a separate heater
- Reduced noise and vibration from solid-state heat pump

#### Applications:

- Analytical Instruments
- Medical Diagnostic Equipment
- Industrial/Electronics Cooling
- Food and Beverage Cooling



### General Specifications:

P/N	TEMA-AP-40-12
Cooling Method/Radiating Method	Plate/Forced Air
Ambient Temperature	-20 to $60^{\circ}C$
Cooling Capacity/Input Power	40W / 50W
Heating Capacity	90W
Fan Current / Noise	0.24A (Radiator) / 40 dB-A
TEC Nominal/Startup Current	3.9A / 5.0A
Nominal/Maximum Voltage	12/15 VDC
Overall Dimension	120mm x 102mm x 80mm
Weight	0.8kg (1.8 lbs)
Lifetime	>70,000 Hours
Cooling Performance Tolerance	10%

**Wakefield-Vette reserves the right to change these specifications without notice**

# Thermoelectric Assembly Performance Specifications

## Air to Plate Thermoelectric Cooler Assembly

TEMA-AP-40-12

### Performance Curve:

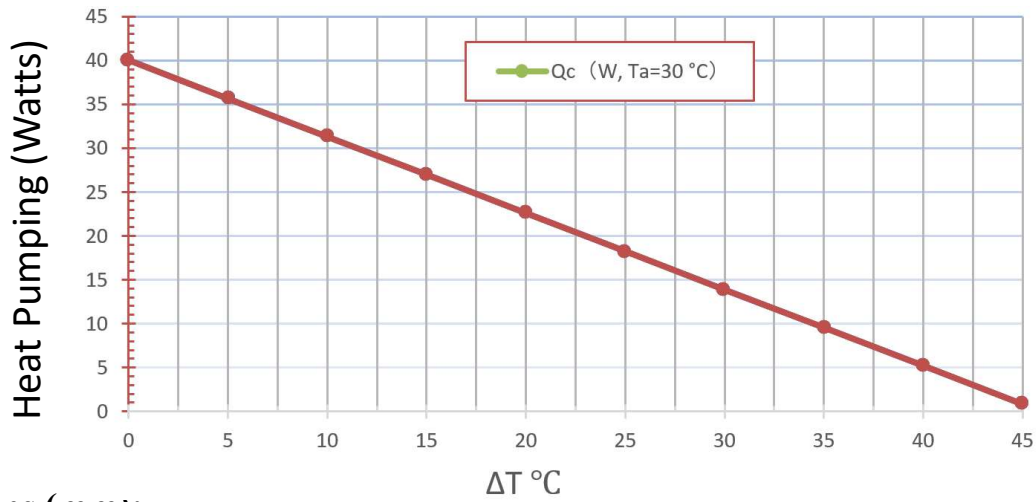

### Dimensions (mm):

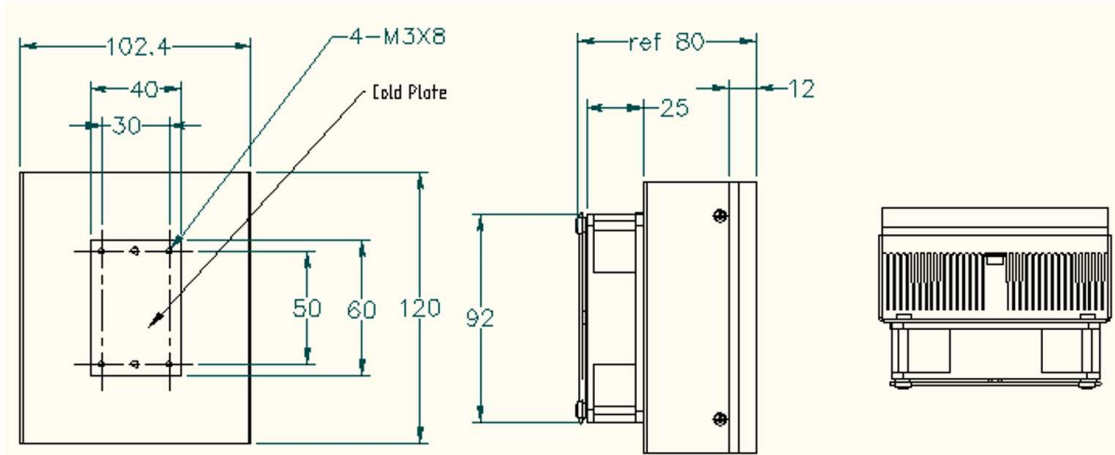

### Installation and Connector (mm):

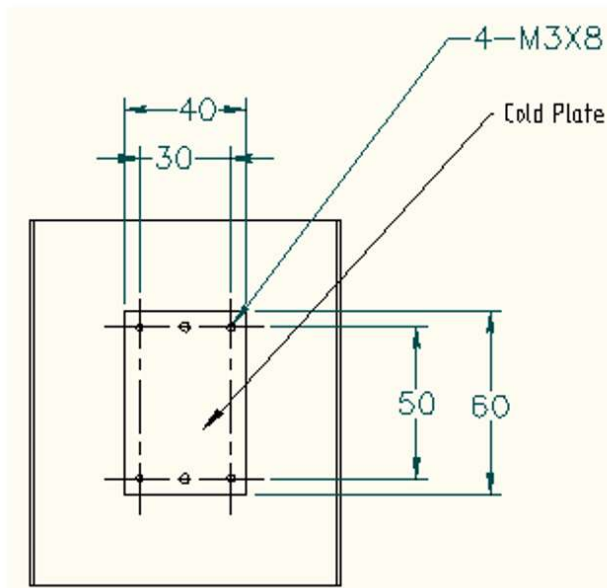

Connector	Wire
1	TEC +
2	TEC -
3	Fan +
4	Fan -

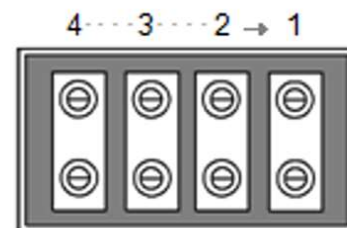

Wakefield-Vette reserves the right to change these specifications without notice

# Thermoelectric Assembly Performance Specifications

## Air to Plate Thermoelectric Cooler Assembly

### TEMA-AP-80-24

The TEMA-AP-80-12 Thermoelectric plate cooler is designed for electronic cabinets and environmental chambers. It can maintain ambient temperatures while removing up to 80W. This model is powered by 24VDC and is essentially maintenance-free, with no filters to change. It can be mounted in any orientation, offering design flexibility with solid-state reliability.

#### Features:

- 80W Capacity at  $DT = 0^{\circ}C$  & Ambient Temperature =  $30^{\circ}C$
- Refrigerant Free – environmentally friendly
- Wide operating temperature range of  $-20^{\circ}C$  to  $+60^{\circ}C$
- Shift between heating and cooling without using a separate heater
- Reduced noise and vibration from solid-state heat pump

#### Applications:

- Analytical Instruments
- Medical Diagnostic Equipment
- Industrial/Electronics Cooling
- Food and Beverage Cooling



#### General Specifications:

P/N	TEMA-AP-80-24
Cooling Method/Radiating Method	Plate/Forced Air
Ambient Temperature	-20 to $60^{\circ}C$
Cooling Capacity/Input Power	80W / 115W
Heating Capacity	190W
Fan Current / Noise	0.35A (Radiator) / 45 dB-A
TEC Nominal/Startup Current	4.2A / 5.3A
Nominal/Maximum Voltage	24/30 VDC
Overall Dimension	203mm x 155mm x 152mm
Weight	3.6kg (8 lbs)
Lifetime	>70,000 Hours
Cooling Performance Tolerance	10%

**Wakefield-Vette reserves the right to change these specifications without notice**

# Thermoelectric Assembly Performance Specifications

## Air to Plate Thermoelectric Cooler Assembly

TEMA-AP-80-24

### Performance Curve:

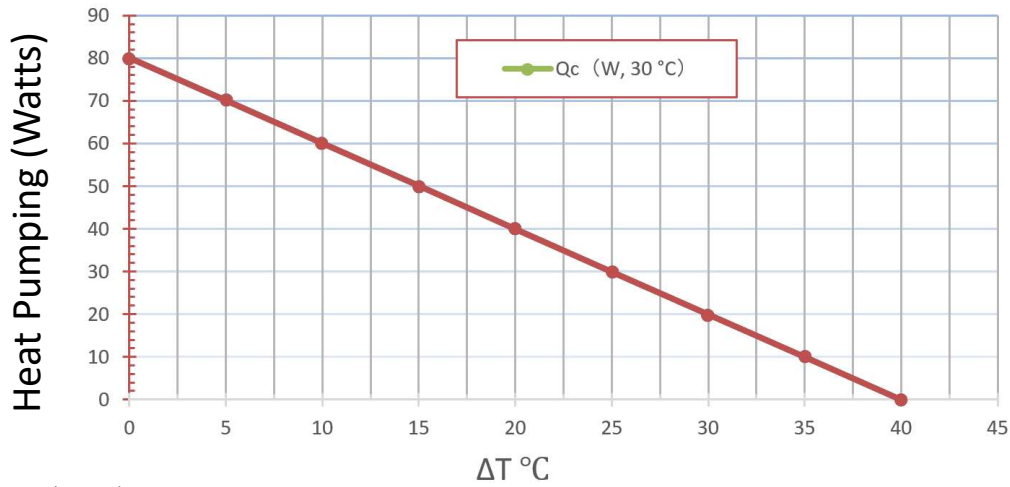

### Dimensions (mm):

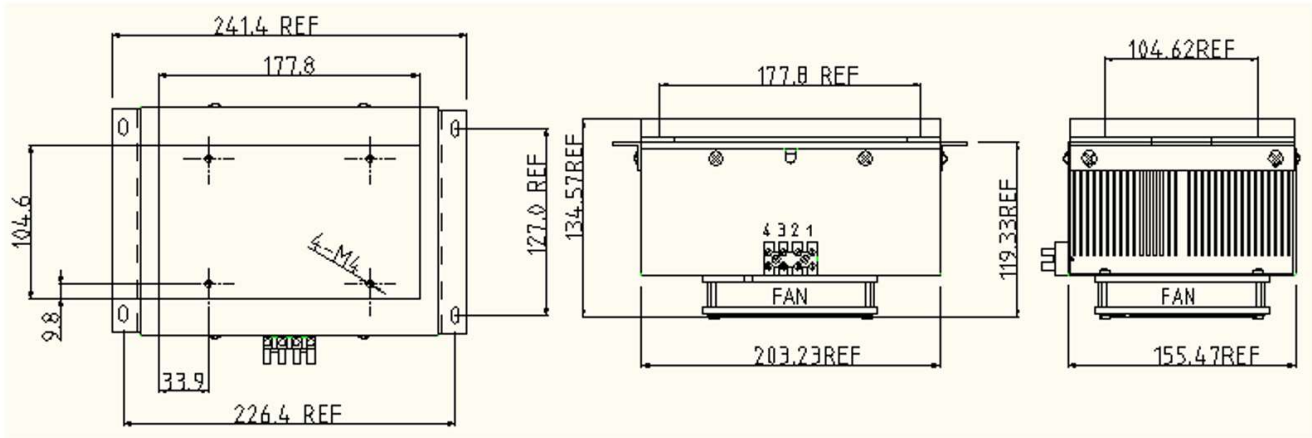

### Installation and Connector (mm):

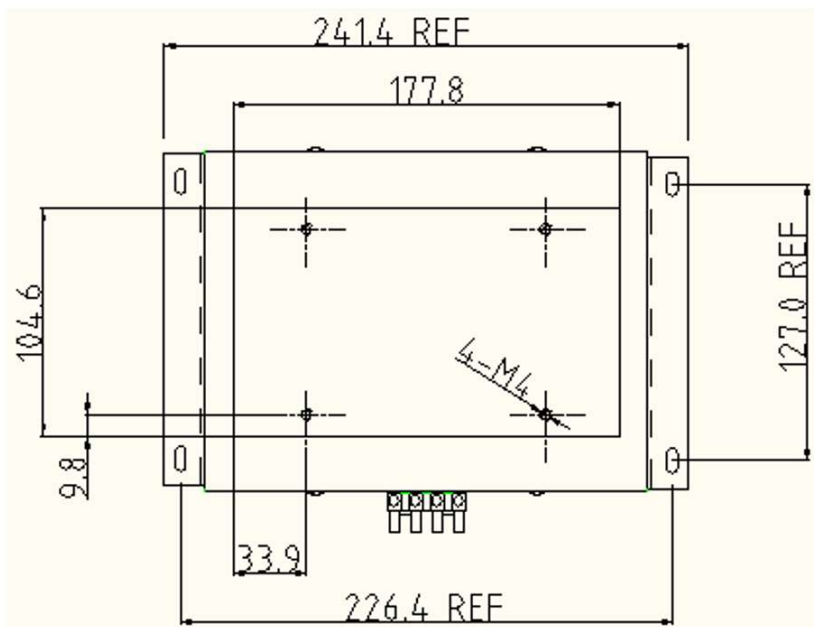

Connector	Wire
1	TEC +
2	TEC -
3	Fan +
4	Fan -

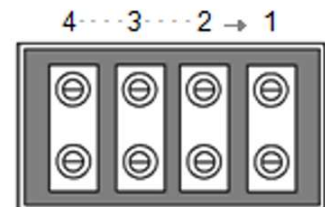

Wakefield-Vette reserves the right to change these specifications without notice