

## Fan Product

Contact:  
Wakefield-Vette  
33 Bridge St.  
Pelham, NH 03076  
603-635-2800  
info@Wakefield-Vette.com

[www.Wakefield-Vette.com](http://www.Wakefield-Vette.com)



# CATALOG

## 1. Vette Introduction

## 2. DC Fan General Specifications

## 3. Part Number System

## 4. DC Fan Technical Information

4.1. Measurement of Air Volume and Static Pressure

4.2. Noise Level Data

4.3. Tachometer Signal & Alarm Signal

## 5. Bearing System

## 6. Axial DC Fan Specification

6.1 30x30x10mm

6.2 40x40x07mm

6.3 40x40x10mm

6.4 40x40x20mm

6.5 45x45x10mm

6.6 50x50x10mm

6.7 50x50x15mm

6.8 60x60x10mm

6.9 60x60x15mm

6.10 60x60x20mm

6.11 60x60x25mm

6.12 70x70x10mm

6.13 70x70x15mm

6.14 70x70x25mm

6.15 80x80x10mm

6.16 80x80x15mm

6.17 80x80x20mm

6.18 80x80x25mm

6.19 92x92x25mm

6.20 92x92x38mm

6.21 120x120x25mm

6.22 120x120x38mm

# General Fan Specifications

## Operating Temperature:

Ball Bearings - 40°C to +70°C (-40°F to +158°F) @ 65% RH  
 Sleeve Bearings - 25°C to +70°C (-18°F to +158°F) @ 65% RH

## Bearing System Life: Code

2 Ball Bearings	D	70,000hours @ 25°C and 65% RH
1 Ball/1 Sleeve	C	50,000hours @ 25°C and 65% RH
1 Ball Bearing	B	50,000hours @ 25°C and 65% RH
Sleeve Bearing	S	30,000hours @ 25°C and 65% RH

## Storage Temperature

All -40°C to +70°C, 35% to 85% RH

## Impeller/Frame

Material PBT, 15% Glass Filled  
 Flammability UL94V-0  
 Color Black-standard. Clear or colored-optional

## Lead Wires

Rating UL1007 or UL1571, Class A 105°C  
 AWG 26 or 28  
 Wire Length 200+/-10mm standard  
 Strip Length 5.0+/-2.0mm standard, stripped and tinned  
 2 Wire Standard Red (+), Black (-)  
 3rd Wire Options Yellow  
 None  
 Locked Rotor Alarm  
 Tachometer/Speed Sensor ( 2 pulses per revolution )  
 Exterior Thermal Sensor

## Insulation Resistance

Standard 10MΩ at 500 VDC minimum ( frame to leads )

## Dielectric Strength

Standard 600VAC (50/60Hz) for 1 seconds with < 10 mA allowable between frame and leads ( CSA (22.2) )

## Noise Data

Standard All noise readings are taken in dBA at 1 meter from air intake side, fan suspended in a semi-anechoic chamber ( <18dBA max )

## Protection

Locked Rotor Standard Feature meets UL standard 72 hour test.  
 Reversed Polarity Standard Feature.  
 Auto Restart Optional  
 Thermal Sensor Optional, fan hub mounted or exterior third wire input

## Shock and Vibration

Vibration Meets 5 minutes for X,Y and Z axes at  
 a. 5-30Hz with, 0.04G peak to peak amplitude  
 b. 30-500Hz, 2G peak to peak amplitude  
 Shock Meets 50G at 11 ms, half-sine, twice for X, Y and Z axes

# DC Fan Catalog Part Numbering System

## Axial Fans



## Blowers



## Frameless Fans

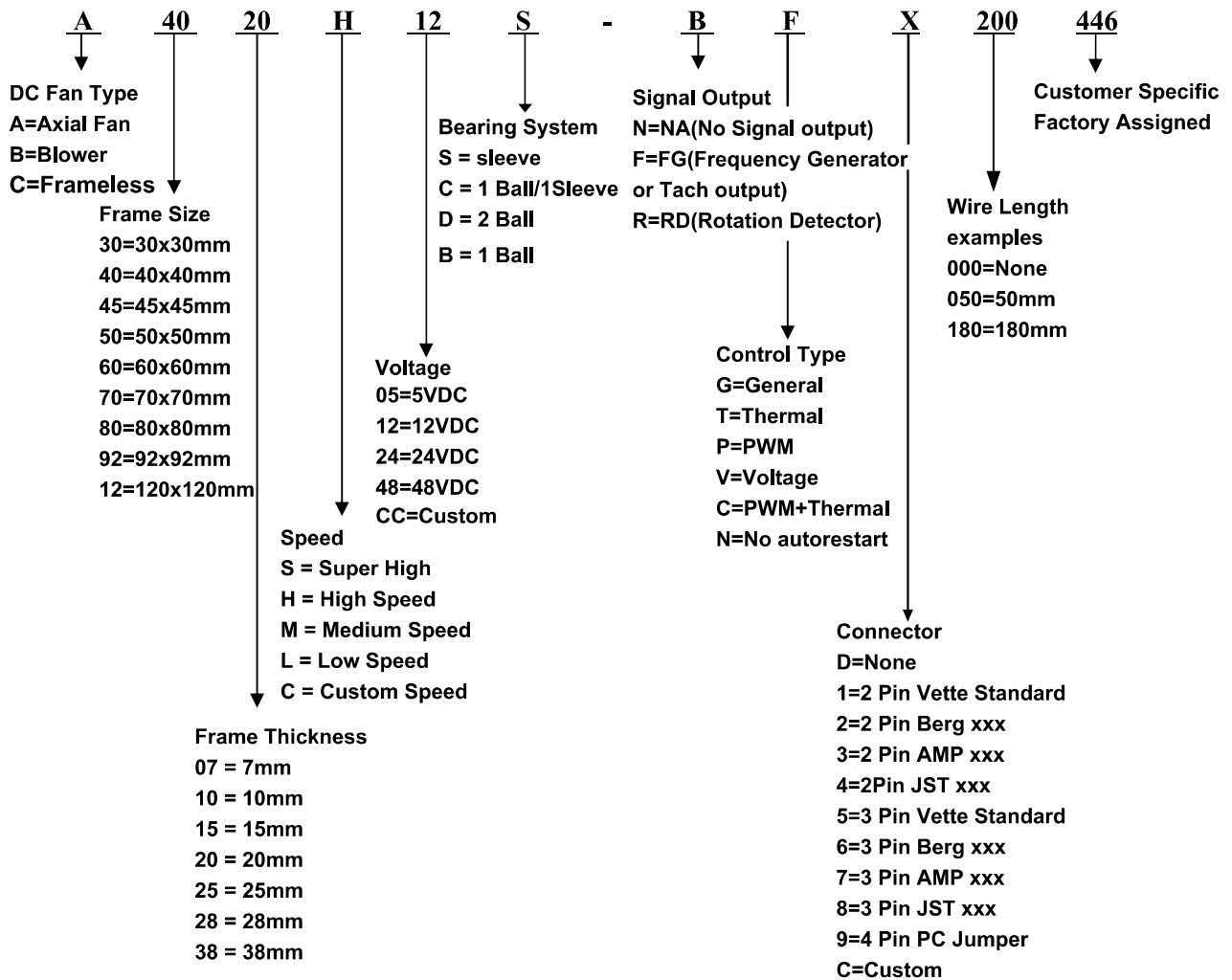

## Bearing System selection



Sleeve



2 Ball Bearing

## Measurement of Air Volume and Static Pressure

Determination of the air performance curve is obtained by using the double chamber method based on AMCA standard. The difference between the pressures before and after the nozzle (differential pressure  $P_n$ ) is measured to obtain the airflow at the nozzle and the different pressures between those in the two chambers (static pressure  $P_s$ ). The airflow is calculated from the differential pressure by using equation (A). The auxiliary blower cancels out the aerodynamic resistance

$$Q = 60 AV \dots (A)$$

Where

Q : Air flow rate ( $m^3/min$ )

A : Nozzle sectional area  $= F/4 D^2 (m^2)$

V : Average flow velocity from nozzle

$$\sqrt{2 \frac{P_n}{r}}$$

r : Specific gravity ( $kg/m^3$ ) of air ( $r=1.2kg/m^3$  at  $20^\circ C$ , 1 atm)

g : Gravitational acceleration =  $9.8m^2/S$

$P_n$  : Differential pressure (mm  $H_2O$ )

$P_s$  : Static pressure (mm  $H_2O$ )

**Maximum air flow:** When opening the nozzle and absorbing the air using the auxiliary blower to make the static pressure zero ( $P_s=0$ ), the differential pressure ( $P_n$ ) between chamber A and chamber B will be at it's maximum. The air flow obtained by applying the differential pressure ( $P_n$ ) to the above equation can be called the maximum air flow.

**Maximum static pressure:** As shown in the figure, when closing the nozzle, the pressure in the chamber A will be at it's maximum. This differential pressure ( $P_s$ ) between the air pressure and the pressure in the chamber A can be called the maximum static pressure.

The Static Pressure Conversion Chart

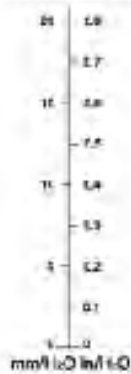

The Airflow Conversion Chart



The Measuring Method-double Chamber

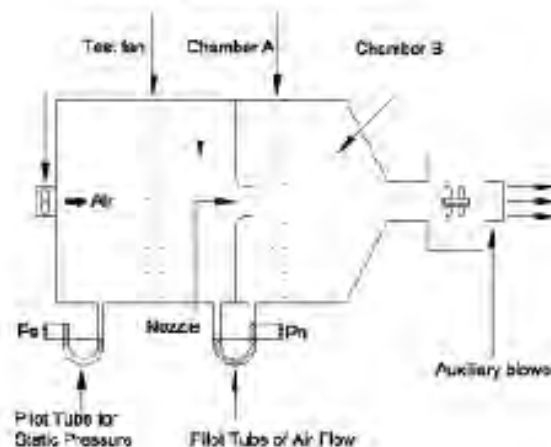

## Noise Level Data

The measurement of noise levels are made in accordance with CNS 8753 (which is very close to DIN45635) which is being tested in a sound proof chamber with a sound level  $L_p < 18\text{dBA}$ .

An elastic mount supported microphone is placed 1 meter from the center line of the fan during the test.

The fan is running without any resistance to airflow.



Sound Pressure Level(SPL) is environmentally dependent and is defined as  $SPL = 20 \log_{10} p/P_{ref}$ ,

and Sound Power Level (PWL) is defined as  $PWL = 10 \log_{10} W/W_{ref}$ .....

$P$ =Pressure

$P_{ref}$ =A reference pressure

$W$ =Acoustic power of the source

$W_{ref}$ =An acoustic reference power

Fan noise data is usually plotted as Sound Pressure Level against the octave frequency bands.



## Fan Bearing System Selection

The following bearing systems are available in the DC fan product line offering.

<u>Bearing System</u>	<u>Order Code</u>	<u>Lifetime Hours</u>	<u>Noise</u>	<u>Relative Cost</u>
Sleeve	S	30,000	Low	Lowest
One Ball*	B	50,000	High	1.7
One Ball/One Sleeve	C	50,000	High	1.8
Two Ball	D	70,000	Highest	2.4

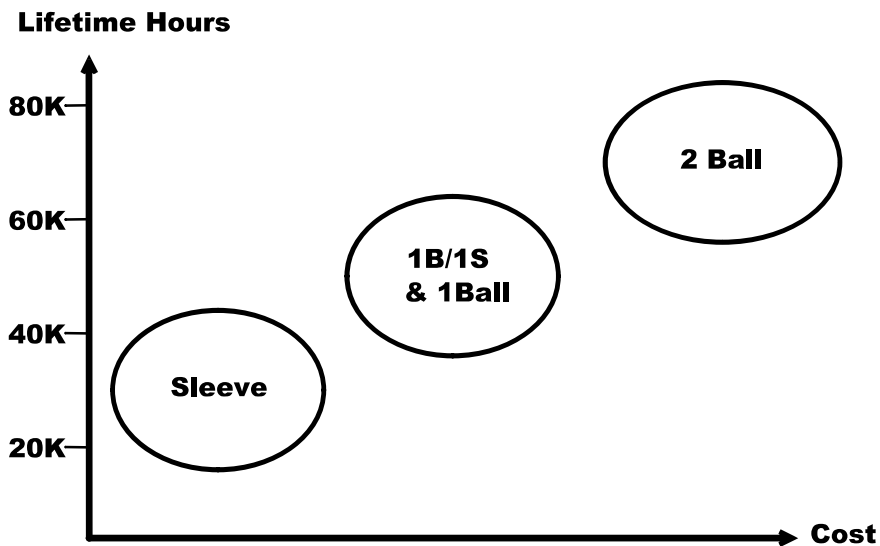

Each bearing system has its own merits, performance and cost. These are explained in the following sections. An important part of fan selection is weighing the cost versus the expected lifetime of the bearing system.

\*Not all bearing systems are available on all fan sizes. For example the One Ball bearing system is only available standard on the 30x30x7 mm fan where the thin 7 mm thick profile is required.

Bearing system life expectancies are rated at 25C, for increased operating temperatures the life expectancy must be de-rated, this is usually done through MTBF calculations and accelerated testing at higher temperatures per MIL-HDBK-217D.

## Sleeve Bearing System

A sleeve bearing, also known as a bushing, is the shortest life bearing system but also has a very low cost. The sleeve and shaft themselves are traditional low cost dissimilar low friction materials and the sleeve is often oil bearing. The sleeve and shaft have a large common surface contact area and exhibit good shock and vibration resistance plus low rotational noise.

Sleeve Bearing

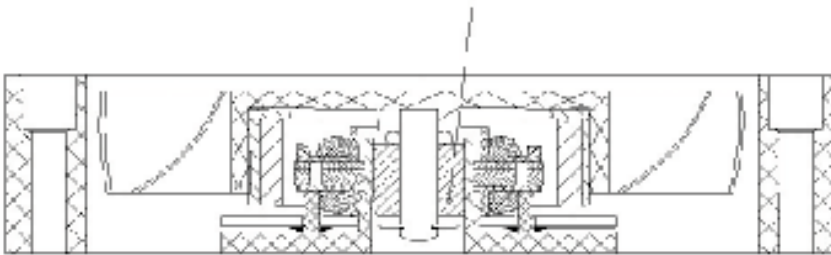

## Ball / Sleeve Bearing Systems

The Ball/Sleeve bearing system is a hybrid between the two ball system and the sleeve bearing system. Since miniature precision ball bearings are a costly component of any fan system; this was the industry's first attempt to reduce cost without reducing life expectancy to that of the standard sleeve alone. The system uses only one of the costly precision miniature ball bearings and one smaller traditional sleeve, and offers some of the advantages of both systems. Negatives of the use of a ball bearing are increased bearing noise (usually only discernable at less than the 1 meter industry test standard) and greater susceptibility to impact damage (due to the high point loads of the ball bearings themselves).

It is a more difficult system to assemble and control and sometimes not favored by fan manufacturers. Modern bearing technology for coated and lubricated sleeve systems has advanced considerably, but this bearing system still remains popular today.

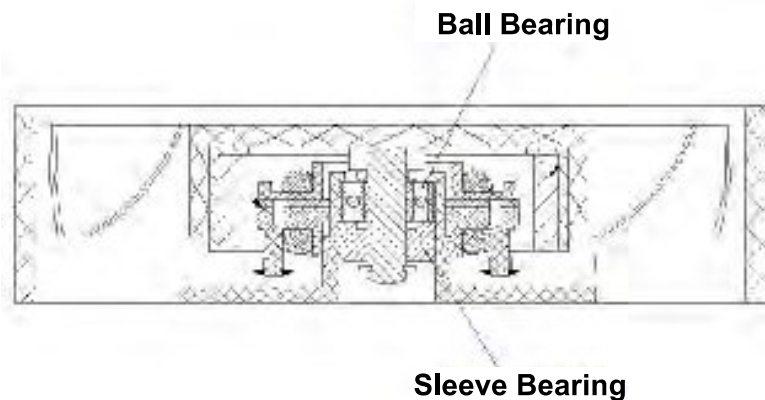

The one ball bearing system is used primarily where mechanical space is very limited. Vette offers this bearing system as a standard only for fans where the frame thickness is very small, such as on the 40x40x7 fan. The susceptibility of impact damage (due to the high point loads of the ball bearings themselves) is lessened on small fans due to the low impeller mass.

## Two Ball Bearing Systems

The two ball bearing system is the industry leader for both long life expectancy at 80,000 hours, but also has the highest cost and noise (at close ranges). The susceptibility to impact damage is less than that of a One Ball system but still far higher than that of a sleeve. One advantage of Ball Bearing systems is that due to the small point load of the balls, they require less power to start rotation as they have less stiction (starting friction) than a sleeve bearing. Two Ball bearing systems are used where long system life is important.

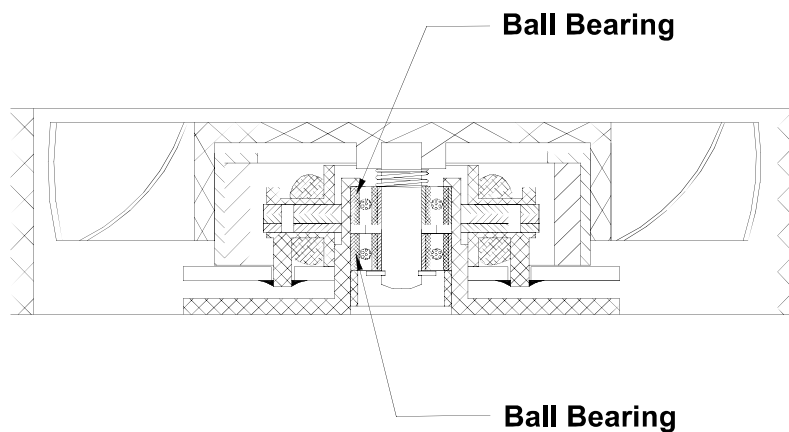

## Bearing Lubrication, Wear and Failure

Typically fans ultimately die because of bearing failure. This is why bearing selection is so important. Bearing failure is normally due to bearing wear and wear is typically from either lack of lubrication or direct damage.

Direct damage can impact or shock to the fan itself. Ball bearing systems with their high point loads are susceptible to this kind of damage. However ball bearing systems are relatively well sealed and lubricated hence their longer life.

Sleeve systems, whether of the basic oil laden bushing type or the more exotics with coatings or seals or lubricants, etc typically will lose lubrication at some point and run dry, leading to wear.

Air flotation bearings will tend to clog with worn bearing surface material.

All fans typically will get noisier and rotate slower as the bearing systems wear and this is a good indicator of pending bearing failure.

# Tachometer Signal & Alarm Signal

## Pulse Sensor (2 Pulse per revolution signal)

Pulse sensors are used for detecting the rotational speed of the fan motor

## Output Circuit Open Collector

### Output Waveform

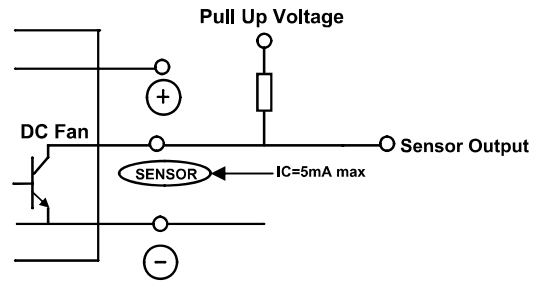
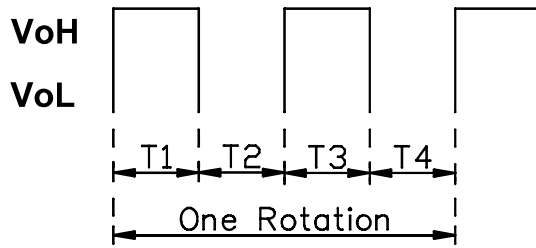

$$T_{1-4} = (1/4)T_o$$

$$T_{1-4} = (1/4)T_o = 60/4 \text{ N(s)}$$

$$N = \text{Fan Rotational Speed (min)}$$

If fan locked on VH, signal stays locked. If fan locked on VL, signal stays at VL for a few hundred MS, then moves to VH.

## Lock Sensor (Locked rotor alarm signal)

Lock sensors are used to detect if the motor is in operation or stopped

## Output Circuit Open Collector

### Output Waveform

Signal given when fan is running

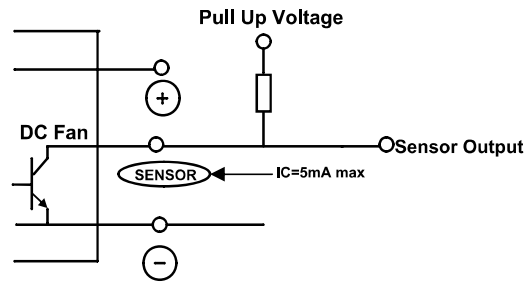
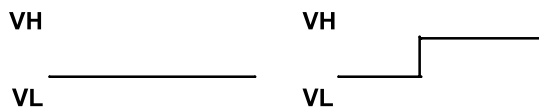

## DC Fan Selection Guide

Model	Frame Size	Available Options							Air Flow Range		Static Pressure Range		Frame Size		
		Axial Fan	(mm)	Auto Restart	Tach	Locked Rotor Alarm	Thermal Sensor Speed Control	PWM Motor Pulse Width Modulation	Connector Selection	Custom Colors	CFM low	CFM high	mm H <sub>2</sub> O low	mm H <sub>2</sub> O high	dBA low
A3010	30X30X10	☺	☺	☺				☺	☺	1.91	3.22	1.74	4.17	24	32
A4007	40X40X07	☺	☺	☺				☺	☺	2.73	3.86	0.89	1.75	24	30
A4010	40X40X10	☺	☺	☺				☺	☺	2.94	5.27	0.84	2.46	25	36
A4020	40X40X20	☺	☺	☺				☺	☺	5.36	8.47	2.03	4.69	25.75	37
A4510	45X45X10	☺	☺	☺				☺	☺	4.71	6.89	0.96	1.79	24	31
A5010	50X50X10	☺	☺	☺				☺	☺	6.46	10.12	1.02	2.15	25	34
A5015	50X50X15	☺	☺	☺				☺	☺	7.4	11.26	1.18	2.54	25	33
A6010	60X60X10	☺	☺	☺				☺	☺	12.01	14.13	1.43	3.04	27	36.5
A6015	60X60X15	☺	☺	☺				☺	☺	13.97	20.16	2.16	4.10	27.5	36.25
A6020	60X60X20	☺	☺	☺	☺	☺		☺	☺	12.46	18.03	2.21	4.36	27	36
A6025	60X60X25	☺	☺	☺	☺	☺		☺	☺	15.86	21.53	3.02	5.32	31	38
A7010	70X70X10	☺	☺	☺				☺	☺	15.74	22.66	1.23	2.36	27	36
A7015	70X70X15	☺	☺	☺		☺		☺	☺	20.07	27.66	1.72	3.12	29.5	37
A7025	70X70X25	☺	☺	☺		☺		☺	☺	20.04	30.01	1.81	3.71	28	38
A8010	80X80X10	☺	☺	☺				☺	☺	12.66	20.63	0.52	1.25	23	29
A8015	80X80X15	☺	☺	☺		☺		☺	☺	20.98	28.59	1.99	3.36	33.7	40.75
A8020	80X80X20	☺	☺	☺		☺		☺	☺	22.28	33.83	1.19	2.46	27	35
A8025	80X80X25	☺	☺	☺		☺		☺	☺	24.22	34.38	1.71	3.14	28	36
A9225	92X92X25	☺	☺	☺		☺		☺	☺	36.78	51.54	1.59	2.91	30	37
A9238	92X92X38	☺	☺	☺		☺		☺	☺	49.31	69.27	3.46	6.44	37	46
A1225	120X120X25	☺	☺	☺		☺		☺	☺	61.83	91.21	2.21	4.26	32	39.0
A1238	120X120X38	☺	☺	☺		☺		☺	☺	97.17	132.20	5.02	8.86	45	53

### General Specifications cont ...

#### Storage Temperature

All -40°C to + 70°C

#### Lead Wires

Rating UL1007 or UL1571, Class A105°C  
 AWG 26 or 28  
 Wire Length 200 +/- 10MM standard  
 Strip Length 5.0 +/- 2.0mm standard, stripped and tinned  
 2 Wire Standard Red (+), Black (-)  
 3rd Wire Option Yellow  
 Locked Rotor Alarm  
 Tachometer/Speed Sensor (2Pulses per revolution)  
 Exterior Thermal Sensor  
 Speed Control

#### Insulation Resistance

Standard 10MΩ at 500VDC minimum (frame to leads)

#### Dielectric Strength

Standard 600 VAC (50/60Hz) for 1 seconds with<10 mA allowable between frame and leads.( CSA 22.2)

#### Noise Data

All noise readings are taken in dBA at 1 meter from air intake side.  
 Fan suspended in a semi-anechoic chamber (<18 dbA max)

#### Protection

Locked Rotor Standard Feature. Meets UL standard 72 hour test.  
 Reversed Polarity Standard Feature.  
 Auto Restart Optional  
 Thermal Sensor Optional, fan hub mounted or exterior third wire input.

#### Shock and Vibration

Vibration Meets 5 minutes for X,Y and Z axis at a 5-30 Hz with .04G peak to peak amplitude  
 b 30-500Hz, 2G peak to peak amplitude  
 Shock Meets 60G at 11ms. half-sine. two times for X.Y and Z axes.



## DC Fan Selection Guide

Model	Frame Size	DC Voltage				Bearing System Selection				Safety Agency	Grams
		5	12	24	48	Standard Sleeve 30K	1Ball 50K MTBF	1B/1S 50K MTBF	2Ball 70K MTBF	UL Approved	
A3010	30X30X10	☺	☺			☺		☺	☺	☺	11.5
A4007	40X40X07	☺	☺				☺			☺	11.5
A4010	40X40X10	☺	☺			☺		☺	☺	☺	14.0
A4020	40X40X20		☺	☺		☺		☺	☺	☺	23.5
A4510	45X45X10	☺	☺			☺		☺	☺	☺	15.6
A5010	50X50X10	☺	☺			☺		☺	☺	☺	17.1
A5015	50X50X15		☺	☺		☺		☺	☺	☺	24.5
A6010	60X60X10	☺	☺			☺		☺	☺	☺	24.0
A6015	60X60X15		☺	☺		☺		☺	☺	☺	24.5
A6020	60X60X20		☺	☺		☺		☺	☺	☺	48.5
A6025	60X60X25		☺	☺	☺	☺		☺	☺	☺	52.8
A7010	70X70X10		☺			☺		☺		☺	40.0
A7015	70X70X15		☺	☺		☺		☺	☺	☺	44.8
A7025	70X70X25		☺	☺	☺	☺		☺	☺	☺	63.0
A8010	80X80X10		☺			☺		☺		☺	37.0
A8015	80X80X15		☺	☺		☺		☺	☺	☺	44.5
A8020	80X80X20		☺	☺		☺		☺	☺	☺	53.6
A8025	80X80X25		☺	☺	☺	☺		☺	☺	☺	63.0
A9225	92X92X25		☺	☺	☺	☺		☺	☺	☺	74.0
A9238	92X92X38		☺	☺	☺				☺	☺	125.0
A1225	120X120X25		☺	☺	☺				☺	☺	140.0
A1238	120X120X38		☺	☺	☺				☺	☺	220.6

### General Specifications

#### Operating Temperature

Ball Bearings	-40°C to +70°C (-40°F to +158°F) @ 65% RH
Sleeve Bearings	-25°C to +70°C (-13°F to +158°F) @ 65% RH

#### Bearing System Life

2 Ball Bearings	D 70,000hours@25°C and65%RH
1Ball/1Sleeve	C 50,000hours@25°C and65%RH
1Ball Bearing	B 50,000hours@25°C and65%RH
Sleeve Bearings	S 30,000hours@25°C and65%RH

#### Impeller/Frame

Material	PBT, 15% Glass Filled
Flammability	UL94V-0
Color	Black-standard, Clear or colored-optional



**\*MOTOR:**

4 pole brushless DC motor

**\*FRAME:**

Injection molded thermal plastic

PBT + 30% GF UL 94V-0

**\*IMPELLER:**

Injection molded thermal plastic

PBT + 15% GF UL 94V-0

**\*INSULATION:**

10MΩ/between unshackled wire

and frame at 500 VDC/m

**\*OPERATION TEMPERATURE & HUMIDITY:**

-10°C~ + 60°C, 35% ~ 85% RH

**\*STORAGE TEMPERATURE & HUMIDITY:**

-40°C~ + 70°C, 35% ~ 85% RH

**\*WIRES:**

UL1007, 28AWG, Red (+), Black (-)

**30\*30\*10 MM SERIES**

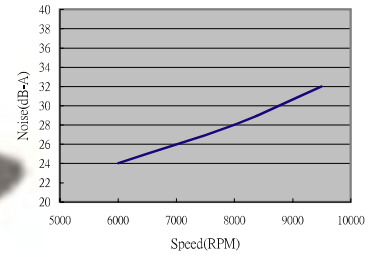

**P&Q CURVE**

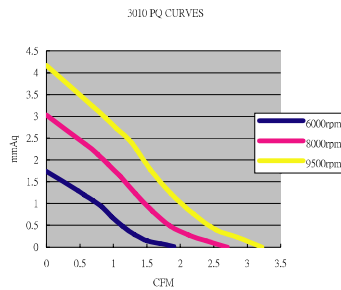

**DIMENSIONS DRAWING**

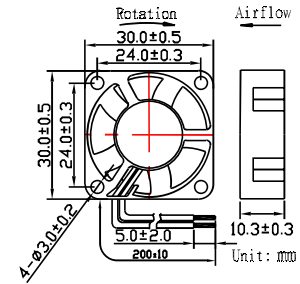

MODEL	Bearing	Rating Voltage	Rated Current	Rated Input Power	Operating Voltage Range	Speed	Air Flow	Static Pressure	Noise	
PART NO.		VDC	Amp	Watts	VDC	RPM	CFM	mm-H <sub>2</sub> O	dBA	
A3010H05D	Two Ball	5	0.25	1.25	4.5 to 6	9500	3.22	4.17	32	
A3010M05D			0.21	1.05	4.5 to 6	8000	2.70	3.03	28	
A3010L05D			0.17	0.85	4.5 to 6	6000	1.91	1.74	24	
A3010H05C	Ball & Sleeve		0.25	1.25	4.5 to 6	9500	3.22	4.17	32	
A3010M05C			0.21	1.05	4.5 to 6	8000	2.70	3.03	28	
A3010L05C			0.17	0.85	4.5 to 6	6000	1.91	1.74	24	
A3010H05S	Sleeve		0.25	1.25	4.5 to 6	9500	3.22	4.17	32	
A3010M05S			0.21	1.05	4.5 to 6	8000	2.70	3.03	28	
A3010L05S			0.17	0.85	4.5 to 6	6000	1.91	1.74	24	
A3010H12D	Two Ball		12	0.11	1.32	6 to 13	9500	3.22	4.17	32
A3010M12D				0.09	1.08	6 to 13	8000	2.70	3.03	28
A3010L12D				0.07	0.84	6 to 13	6000	1.91	1.74	24
A3010H12C	Ball & Sleeve	0.11		1.32	6 to 13	9500	3.22	4.17	32	
A3010M12C		0.09		1.08	6 to 13	8000	2.70	3.03	28	
A3010L12C		0.07		0.84	6 to 13	6000	1.91	1.74	24	
A3010H12S	Sleeve	0.11		1.32	6 to 13	9500	3.22	4.17	32	
A3010M12S		0.09		1.08	6 to 13	8000	2.70	3.03	28	
A3010L12S		0.07		0.84	6 to 13	6000	1.91	1.74	24	

**\*MOTOR:**

4 pole brushless DC motor

**\*FRAME:**

Injection molded thermal plastic

PBT + 30% GF UL 94V-0

**\*IMPELLER:**

Injection molded thermal plastic

PBT+15% GF UL 94V-0

**\*INSULATION:**

10MΩ/between unshackled wire

and frame at 500 VDC/m

**\*OPERATION TEMPERATURE & HUMIDITY:**

-10°C ~ +60°C, 35% ~ 85% RH

**\*STORAGE TEMPERATURE & HUMIDITY:**

-40°C ~ +70°C, 35% ~ 85% RH

**\*WIRES:**

UL1061, 28AWG, Red (+), Black (-)

**40\*40\*7 MM SERIES**

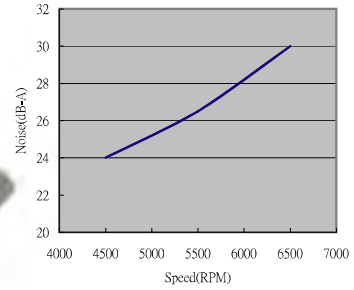

**P&Q CURVE**

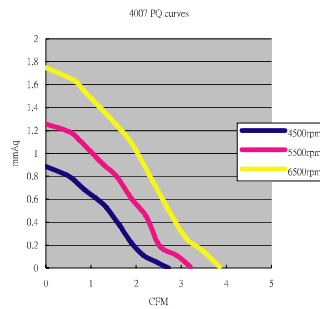

**DIMENSIONS DRAWING**

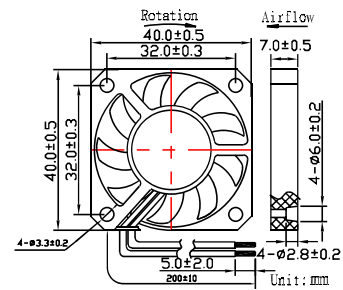

MODEL	Bearing	Rating Voltage	Rated Current	Rated Input Power	Operating Voltage Range	Speed	Air Flow	Static Pressure	Noise
PART NO.		VDC	Amp	Watts	VDC	RPM	CFM	mm-H <sub>2</sub> O	dBA
A4007H05B	One Ball	5	0.15	0.75	4 to 6	6500	3.86	1.75	30
A4007M05B			0.13	0.65	4 to 6	5500	3.21	1.26	26.5
A4007L05B			0.11	0.55	4 to 6	4500	2.73	0.89	24
A4007H12B		12	0.12	1.44	6 to 13	6500	3.86	1.75	30
A4007M12B			0.10	1.2	7 to 13	5500	3.21	1.26	26.5
A4007L12B			0.08	0.96	7 to 13	4500	2.73	0.89	24

**\*MOTOR:**

4 pole brushless DC motor

**\*FRAME:**

Injection molded thermal plastic

PBT + 30% GF UL 94V-0

**\*IMPELLER:**

Injection molded thermal plastic

PBT + 15% GF UL 94V-0

**\*INSULATION:**

10MΩ/between unshackled wire

and frame at 500 VDC/m

**\*OPERATION TEMPERATURE & HUMIDITY:**

-10°C ~ +60°C, 35% ~ 85% RH

**\*STORAGE TEMPERATURE & HUMIDITY:**

-40°C ~ +70°C, 35% ~ 85% RH

**\*WIRES:**

UL1007, 28AWG, Red (+), Black (-)

**40\*40\*10 MM SERIES**

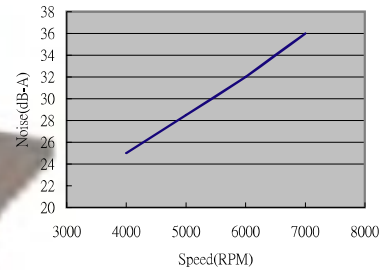

**P&Q CURVE**

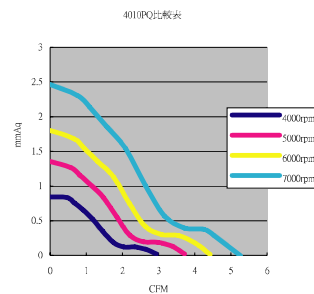

**DIMENSIONS DRAWING**

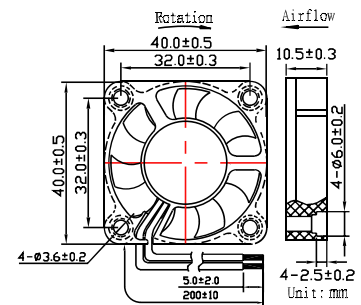

MODEL	Bearing	Rating Voltage	Rated Current	Rated Input Power	Operating Voltage Range	Speed	Air Flow	Static Pressure	Noise	
PART NO.		VDC	Amp	Watts	VDC	RPM	CFM	mm-H <sub>2</sub> O	dBA	
A4010H12D	Two Ball	5	0.20	1.00	4 to 6	6000	4.43	1.80	32	
A4010M12D			0.16	0.80	4 to 6	5000	3.72	1.35	28.5	
A4010L12D			0.14	0.70	4 to 6	4000	2.94	0.84	25	
A4010H12C	Ball & Sleeve		0.20	1.00	4 to 6	6000	4.43	1.80	32	
A4010M12C			0.16	0.80	4 to 6	5000	3.72	1.35	28.5	
A4010L12C			0.14	0.70	4 to 6	4000	2.94	0.84	25	
A4010H12S	Sleeve		0.20	1.00	4 to 6	6000	4.43	1.80	32	
A4010M12S			0.16	0.80	4 to 6	5000	3.72	1.35	28.5	
A4010L12S			0.14	0.70	4 to 6	4000	2.94	0.84	25	
A4010S12D	Two Ball		12	0.15	1.80	6 to 13	7000	5.27	2.46	36
A4010H12D				0.11	1.32	6 to 13	6000	4.43	1.80	32
A4010M12D				0.09	1.08	7 to 13	5000	3.72	1.35	28.5
A4010L12D	0.07	0.84		7 to 13	4000	2.94	0.84	25		
A4010S12C	Ball & Sleeve	0.15		1.80	6 to 13	7000	5.27	2.46	36	
A4010H12C		0.11		1.32	6 to 13	6000	4.43	1.80	32	
A4010M12C		0.09		1.08	7 to 13	5000	3.72	1.35	28.5	
A4010L12C	0.07	0.84		7 to 13	4000	2.94	0.84	25		
A4010S12S	Sleeve	0.15		1.80	6 to 13	7000	5.27	2.46	36	
A4010H12S		0.11		1.32	6 to 13	6000	4.43	1.80	32	
A4010M12S		0.09		1.08	7 to 13	5000	3.72	1.35	28.5	
A4010L12S	0.07	0.84		7 to 13	4000	2.94	0.84	25		

**\*MOTOR:**

4 pole brushless DC motor

**\*FRAME:**

Injection molded thermal plastic

PBT + 30% GF UL 94V-0

**\*IMPELLER:**

Injection molded thermal plastic

PBT + 15% GF UL 94V-0

**\*INSULATION:**

10MΩ/between unshackled wire

and frame at 500 VDC/m

**\*OPERATION TEMPERATURE & HUMIDITY:**

-10°C~ +60°C, 35% ~ 85% RH

**\*STORAGE TEMPERATURE & HUMIDITY:**

-40°C~ +70°C, 35% ~ 85% RH

**\*WIRES:**

UL1007, 28AWG, Red (+), Black (-)

**40\*40\*20 MM SERIES**

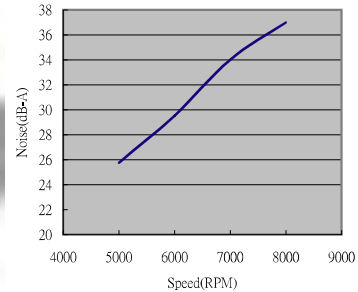

**P&Q CURVE**

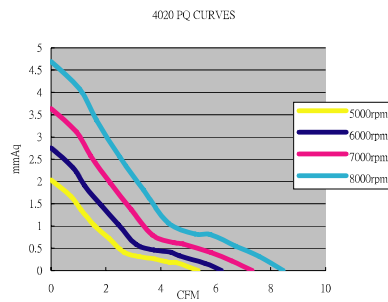

**DIMENSIONS DRAWING**

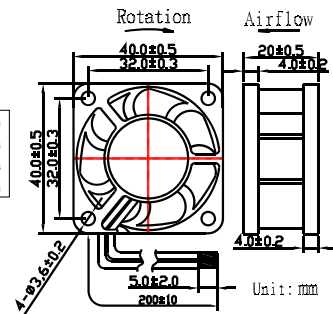

MODEL	Bearing	Rating Voltage	Rated Current	Rated Input Power	Operating Voltage Range	Speed	Air Flow	Static Pressure	Noise
PART NO.		VDC	Amp	Watts	VDC	RPM	CFM	mm-H <sub>2</sub> O	dBA
A4020S12D	Two Ball	12	0.24	2.88	6 to 13	8000	8.47	4.69	37
A4020H12D			0.18	2.16	6 to 13	7000	7.33	3.64	34
A4020M12D			0.15	1.80	6 to 13	6000	6.22	2.75	29.5
A4020L12D			0.13	1.56	6 to 13	5000	5.36	2.03	25.75
A4020S12C	Ball & Sleeve		0.24	2.88	6 to 13	8000	8.47	4.69	37
A4020H12C			0.18	2.16	6 to 13	7000	7.33	3.64	34
A4020M12C			0.15	1.80	6 to 13	6000	6.22	2.75	29.5
A4020L12C			0.13	1.56	6 to 13	5000	5.36	2.03	25.75
A4020S12S	Sleeve	0.24	2.88	6 to 13	8000	8.47	4.69	37	
A4020H12S		0.18	2.16	6 to 13	7000	7.33	3.64	34	
A4020M12S		0.15	1.80	6 to 13	6000	6.22	2.75	29.5	
A4020L12S		0.13	1.56	6 to 13	5000	5.36	2.03	25.75	
A4020S24D	Two Ball	24	0.16	3.84	12 to 26	8000	8.47	4.69	37
A4020H24D			0.12	2.88	12 to 26	7000	7.33	3.64	34
A4020M24D			0.1	2.40	12 to 26	6000	6.22	2.75	29.5
A4020L24D			0.08	1.92	12 to 26	5000	5.36	2.03	25.75
A4020S24C	Ball & Sleeve		0.16	3.84	12 to 26	8000	8.47	4.69	37
A4020H24C			0.12	2.88	12 to 26	7000	7.33	3.64	34
A4020M24C			0.1	2.40	12 to 26	6000	6.22	2.75	29.5
A4020L24C			0.08	1.92	12 to 26	5000	5.36	2.03	25.75
A4020S24S	Sleeve	0.16	3.84	12 to 26	8000	8.47	4.69	37	
A4020H24S		0.12	2.88	12 to 26	7000	7.33	3.64	34	
A4020M24S		0.1	2.40	12 to 26	6000	6.22	2.75	29.5	
A4020L24S		0.08	1.92	12 to 26	5000	5.36	2.03	25.75	

**\*MOTOR:**

4 pole brushless DC motor

**\*FRAME:**

Injection molded thermal plastic

PBT + 30% GF UL 94V-0

**\*IMPELLER:**

Injection molded thermal plastic

PBT + 15% GF UL 94V-0

**\*INSULATION:**

10MΩ/between unshackled wire

and frame at 500 VDC/m

**\*OPERATION TEMPERATURE & HUMIDITY:**

-10°C~ + 60°C, 35% ~ 85% RH

**\*STORAGE TEMPERATURE & HUMIDITY:**

-40°C~ + 70°C, 35% ~ 85% RH

**\*WIRES:**

UL1007, 28AWG, Red (+), Black (-)

**45\*45\*10 MM SERIES**

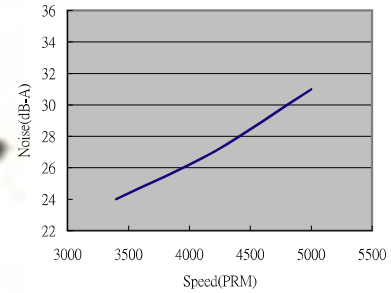

**P&Q CURVE**

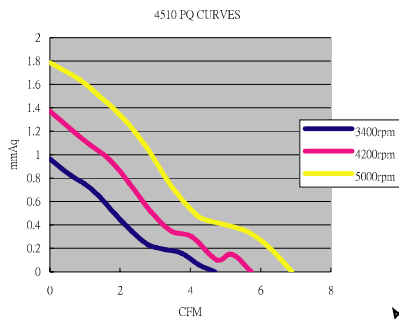

**DIMENSIONS DRAWING**

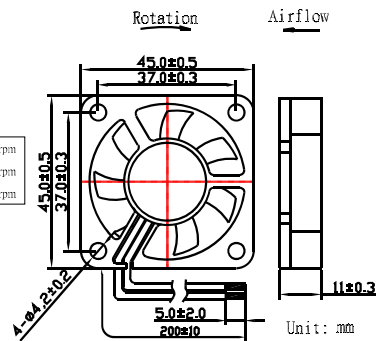

MODEL	Bearing	Rating Voltage	Rated Current	Rated Input Power	Operating Voltage Range	Speed	Air Flow	Static Pressure	Noise
PART NO.		VDC	Amp	Watts	VDC	RPM	CFM	mm-H <sub>2</sub> O	dBA
A4510H05D	Two Ball	5	0.28	1.40	4.5 to 6	5000	6.89	1.79	31
A4510M05D			0.24	1.20	4.5 to 6	4200	5.74	1.37	27
A4510L05D			0.20	1.00	4.5 to 6	3400	4.71	0.96	24
A4510H05C	Ball & Sleeve		0.28	1.40	4.5 to 6	5000	6.89	1.79	31
A4510M05C			0.24	1.20	4.5 to 6	4200	5.74	1.37	27
A4510L05C			0.20	1.00	4.5 to 6	3400	4.71	0.96	24
A4510H05S	Sleeve		0.28	1.40	4.5 to 6	5000	6.89	1.79	31
A4510M05S			0.24	1.20	4.5 to 6	4200	5.74	1.37	27
A4510L05S			0.20	1.00	4.5 to 6	3400	4.71	0.96	24
A4510H12D	Two Ball	12	0.13	1.56	6 to 13	5000	6.89	1.79	31
A4510M12D			0.11	1.32	7 to 13	4200	5.74	1.37	27
A4510L12D			0.09	1.08	7 to 13	3400	4.71	0.96	24
A4510H12C	Ball & Sleeve		0.13	1.56	6 to 13	5000	6.89	1.79	31
A4510M12C			0.11	1.32	7 to 13	4200	5.74	1.37	27
A4510L12C			0.09	1.08	7 to 13	3400	4.71	0.96	24
A4510H12S	Sleeve		0.13	1.56	6 to 13	5000	6.89	1.79	31
A4510M12S			0.11	1.32	7 to 13	4200	5.74	1.37	27
A4510L12S			0.09	1.08	7 to 13	3400	4.71	0.96	24

**\*MOTOR:**

4 pole brushless DC motor

**\*FRAME:**

Injection molded thermal plastic  
PBT + 30% GF UL 94V-0

**\*IMPELLER:**

Injection molded thermal plastic  
PBT + 15% GF UL 94V-0

**\*INSULATION:**

10M $\Omega$ /between unshackled wire  
and frame at 500 VDC/m

**\*OPERATION TEMPERATURE & HUMIDITY:**

-10°C~ + 60°C, 35% ~ 85% RH

**\*STORAGE TEMPERATURE & HUMIDITY:**

-40°C~ + 70°C, 35% ~ 85% RH

**\*WIRES:**

UL1007, 28AWG, Red (+), Black (-)

**50\*50\*10 MM SERIES**

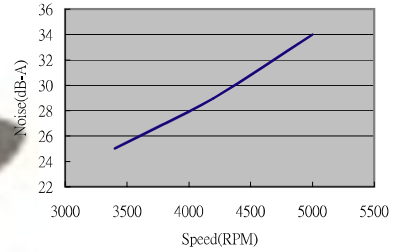

**P&Q CURVE**

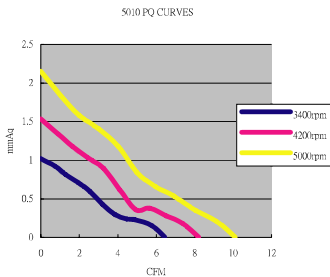

**DIMENSIONS DRAWING**

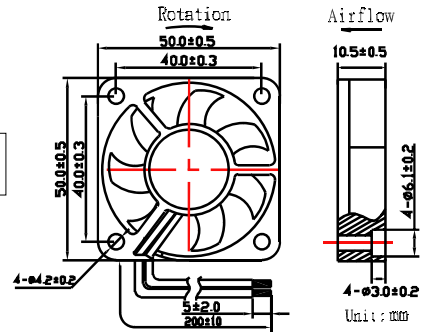

MODEL	Bearing	Rating Voltage	Rated Current	Rated Input Power	Operating Voltage Range	Speed	Air Flow	Static Pressure	Noise
PART NO.		VDC	Amp	Watts	VDC	RPM	CFM	mm-H <sub>2</sub> O	dBA
A5010H05D	Two Ball	5	0.30	1.50	4.5 to 6	5000	10.12	2.15	34
A5010M05D			0.24	1.20	4.5 to 6	4200	8.22	1.54	29
A5010L05D			0.18	0.90	4.5 to 6	3400	6.46	1.02	25
A5010H05C	Ball & Sleeve		0.30	1.50	4.5 to 6	5000	10.12	2.15	34
A5010M05C			0.24	1.20	4.5 to 6	4200	8.22	1.54	29
A5010L05C			0.18	0.90	4.5 to 6	3400	6.46	1.02	25
A5010H05S	Sleeve	0.30	1.50	4.5 to 6	5000	10.12	2.15	34	
A5010M05S		0.24	1.20	4.5 to 6	4200	8.22	1.54	29	
A5010L05S		0.18	0.90	4.5 to 6	3400	6.46	1.02	25	
A5010H12D	Two Ball	12	0.14	1.68	6 to 13	5000	10.12	2.15	34
A5010M12D			0.11	1.32	7 to 13	4200	8.22	1.54	29
A5010L12D			0.08	0.96	7 to 13	3400	6.46	1.02	25
A5010H12C	Ball & Sleeve		0.14	1.68	6 to 13	5000	10.12	2.15	34
A5010M12C			0.11	1.32	7 to 13	4200	8.22	1.54	29
A5010L12C			0.08	0.96	7 to 13	3400	6.46	1.02	25
A5010H12S	Sleeve	0.14	1.68	6 to 13	5000	10.12	2.15	34	
A5010M12S		0.11	1.32	7 to 13	4200	8.22	1.54	29	
A5010L12S		0.08	0.96	7 to 13	3400	6.46	1.02	25	



**\*MOTOR:**

4 pole brushless DC motor

**\*FRAME:**

Injection molded thermal plastic

PBT + 30% GF UL 94V-0

**\*IMPELLER:**

Injection molded thermal plastic

PBT + 15% GF UL 94V-0

**\*INSULATION:**

10MΩ/between unshackled wire

and frame at 500 VDC/m

**\*OPERATION TEMPERATURE & HUMIDITY:**

-10°C ~ +60°C, 35% ~ 85% RH

**\*STORAGE TEMPERATURE & HUMIDITY:**

-40°C ~ +70°C, 35% ~ 85% RH

**\*WIRES:**

UL1007, 28AWG, Red (+), Black (-)

**50\*50\*15 MM SERIES**

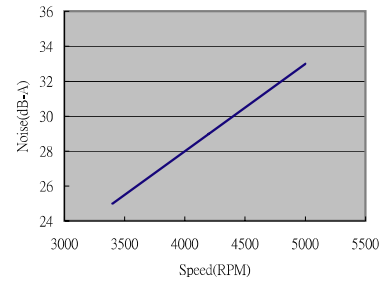

**P&Q CURVE**

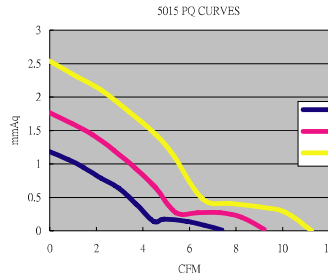

**DIMENSIONS DRAWING**

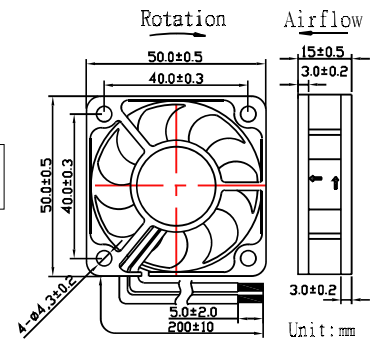

MODEL	Bearing	Rating Voltage	Rated Current	Rated Input Power	Operating Voltage Range	Speed	Air Flow	Static Pressure	Noise	
PART NO.		VDC	Amp	Watts	VDC	RPM	CFM	mm-H <sub>2</sub> O	dBA	
A5015H12D	Two Ball	12	0.16	1.92	6 to 13	5000	11.26	2.54	33	
A5015M12D			0.13	1.56	6 to 13	4200	9.23	1.76	29	
A5015L12D			0.08	0.96	6 to 13	3400	7.40	1.18	25	
A5015H12C	Ball & Sleeve		0.16	1.92	6 to 13	5000	11.26	2.54	33	
A5015M12C			0.13	1.56	6 to 13	4200	9.23	1.76	29	
A5015L12C			0.08	0.96	6 to 13	3400	7.40	1.18	25	
A5015H12S	Sleeve		0.16	1.92	6 to 13	5000	11.26	2.54	33	
A5015M12S			0.13	1.56	6 to 13	4200	9.23	1.76	29	
A5015L12S			0.08	0.96	6 to 13	3400	7.40	1.18	25	
A5015H24D	Two Ball		24	0.10	2.40	12 to 26	5000	11.26	2.54	33
A5015M24D				0.08	1.92	12 to 26	4200	9.23	1.76	29
A5015L24D				0.06	1.44	12 to 26	3400	7.40	1.18	25
A5015H24C	Ball & Sleeve	0.10		2.40	12 to 26	5000	11.26	2.54	33	
A5015M24C		0.08		1.92	12 to 26	4200	9.23	1.76	29	
A5015L24C		0.06		1.44	12 to 26	3400	7.40	1.18	25	
A5015H24S	Sleeve	0.10		2.40	12 to 26	5000	11.26	2.54	33	
A5015M24S		0.08		1.92	12 to 26	4200	9.23	1.76	29	
A5015L24S		0.06		1.44	12 to 26	3400	7.40	1.18	25	

**\*MOTOR:**

4 pole brushless DC motor

**\*FRAME:**

Injection molded thermal plastic

PBT + 30% GF UL 94V-0

**\*IMPELLER:**

Injection molded thermal plastic

PBT + 15% GF UL 94V-0

**\*INSULATION:**

10MΩ/between unshackled wire

and frame at 500 VDC/m

**\*OPERATION TEMPERATURE & HUMIDITY:**

-10°C~ + 60°C, 35% ~ 85% RH

**\*STORAGE TEMPERATURE & HUMIDITY:**

-40°C~ + 70°C, 35% ~ 85% RH

**\*WIRES:**

UL1007, 28AWG, Red (+), Black (-)

**60\*60\*10 MM SERIES**

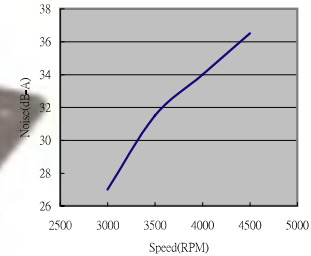

**P&Q CURVE**

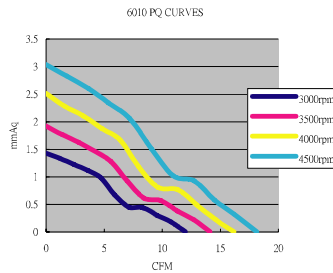

**DIMENSIONS DRAWING**

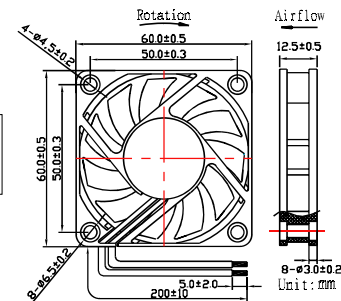

MODEL	Bearing	Rating Voltage	Rated Current	Rated Input Power	Operating Voltage Range	Speed	Air Flow	Static Pressure	Noise
PART NO.		VDC	Amp	Watts	VDC	RPM	CFM	mm-H <sub>2</sub> O	dBA
A6010S05D	Two Ball	5	0.35	1.75	4.5 to 6	4500	18.13	3.04	36.5
A6010H05D			0.30	1.50	4.5 to 6	4000	16.19	2.51	34
A6010M05D			0.24	1.20	4.5 to 6	3500	14.13	1.92	31.5
A6010L05D			0.18	0.90	4.5 to 6	3000	12.01	1.43	27
A6010S05C	Ball & Sleeve		0.35	1.75	4.5 to 6	4500	18.13	3.04	36.5
A6010H05C			0.30	1.50	4.5 to 6	4000	16.19	2.51	34
A6010M05C			0.24	1.20	4.5 to 6	3500	14.13	1.92	31.5
A6010L05C			0.18	0.90	4.5 to 6	3000	12.01	1.43	27
A6010S05S	Sleeve	0.35	1.75	4.5 to 6	4500	18.13	3.04	36.5	
A6010H05S		0.30	1.50	4.5 to 6	4000	16.19	2.51	34	
A6010M05S		0.24	1.20	4.5 to 6	3500	14.13	1.92	31.5	
A6010L05S		0.18	0.90	4.5 to 6	3000	12.01	1.43	27	
A6010S12D	Two Ball	12	0.18	2.16	6 to 13	4500	18.13	3.04	36.5
A6010H12D			0.14	1.68	6 to 13	4000	16.19	2.51	34
A6010M12D			0.11	1.32	6 to 13	3500	14.13	1.92	31.5
A6010L12D			0.08	0.96	6 to 13	3000	12.01	1.43	27
A6010S12C	Ball & Sleeve		0.18	2.16	6 to 13	4500	18.13	3.04	36.5
A6010H12C			0.14	1.68	6 to 13	4000	16.19	2.51	34
A6010M12C			0.11	1.32	6 to 13	3500	14.13	1.92	31.5
A6010L12C			0.08	0.96	6 to 13	3000	12.01	1.43	27
A6010S12S	Sleeve		0.18	2.16	6 to 13	4500	18.13	3.04	36.5
A6010H12S			0.14	1.68	6 to 13	4000	16.19	2.51	34
A6010M12S			0.11	1.32	6 to 13	3500	14.13	1.92	31.5
A6010L12S			0.08	0.96	6 to 13	3000	12.01	1.43	27

**\*MOTOR:**

4 pole brushless DC motor

**\*FRAME:**

Injection molded thermal plastic

PBT + 30% GF UL 94V-0

**\*IMPELLER:**

Injection molded thermal plastic

PBT + 15% GF UL 94V-0

**\*INSULATION:**

10MΩ/between unshackled wire and frame at 500 VDC/m

**60\*60\*15 MM SERIES**

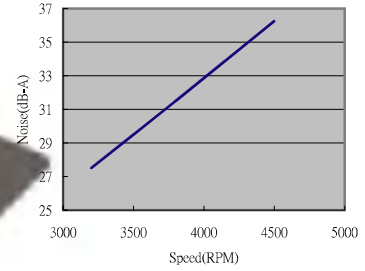

**\*OPERATION TEMPERATURE & HUMIDITY:**

-10°C ~ +60°C, 35% ~ 85% RH

**\*STORAGE TEMPERATURE & HUMIDITY:**

-40°C ~ +70°C, 35% ~ 85% RH

**\*WIRES:**

UL1007, 26AWG, Red (+), Black (-)

**P&Q CURVE**

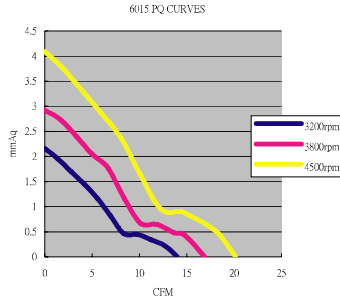

**DIMENSIONS DRAWING**

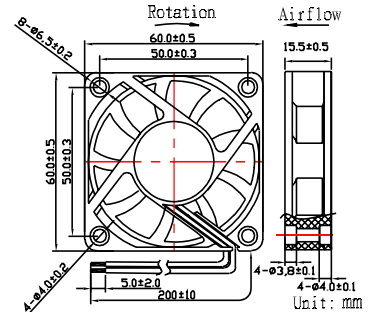

MODEL	Bearing	Rating Voltage	Rated Current	Rated Input Power	Operating Voltage Range	Speed	Air Flow	Static Pressure	Noise
PART NO.		VDC	Amp	Watts	VDC	RPM	CFM	mm-H <sub>2</sub> O	dBA
A6015H12D	Two Ball	12	0.2	2.4	6 to 13	4500	20.16	4.10	36.25
A6015M12D			0.17	2.04	6 to 13	3800	16.90	2.92	31.5
A6015L12D			0.14	1.68	6 to 13	3200	13.97	2.16	27.5
A6015H12C	Ball & Sleeve		0.2	2.4	6 to 13	4500	20.16	4.10	36.25
A6015M12C			0.17	2.04	6 to 13	3800	16.90	2.92	31.5
A6015L12C			0.14	1.68	6 to 13	3200	13.97	2.16	27.5
A6015H12S	Sleeve		0.2	2.4	6 to 13	4500	20.16	4.10	36.25
A6015M12S			0.17	2.04	6 to 13	3800	16.90	2.92	31.5
A6015L12S			0.14	1.68	6 to 13	3200	13.97	2.16	27.5
A6015H24D	Two Ball	24	0.12	2.88	12 to 26	4500	20.16	4.10	36.25
A6015M24D			0.10	2.40	12 to 26	3800	16.90	2.92	31.5
A6015L24D			0.08	1.92	12 to 26	3200	13.97	2.16	27.5
A6015H24C	Ball & Sleeve		0.12	2.88	12 to 26	4500	20.16	4.10	36.25
A6015M24C			0.10	2.40	12 to 26	3800	16.90	2.92	31.5
A6015L24C			0.08	1.92	12 to 26	3200	13.97	2.16	27.5
A6015H24S	Sleeve		0.12	2.88	12 to 26	4500	20.16	4.10	36.25
A6015M24S			0.10	2.40	12 to 26	3800	16.90	2.92	31.5
A6015L24S			0.08	1.92	12 to 26	3200	13.97	2.16	27.5

**\*MOTOR:**

4 pole brushless DC motor

**\*FRAME:**

Injection molded thermal plastic

PBT + 30% GF UL 94V-0

**\*IMPELLER:**

Injection molded thermal plastic

PBT + 15% GF UL 94V-0

**\*INSULATION:**

10MΩ/between unshackled wire

and frame at 500 VDC/m

**\*OPERATION TEMPERATURE & HUMIDITY:**

-10°C ~ +60°C, 35% ~ 85% RH

**\*STORAGE TEMPERATURE & HUMIDITY:**

-40°C ~ +70°C, 35% ~ 85% RH

**\*WIRES:**

UL1007, 26AWG, Red (+), Black (-)

**60\*60\*20 MM SERIES**

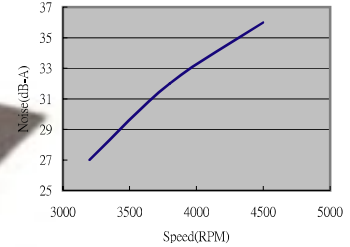

**P&Q CURVE**

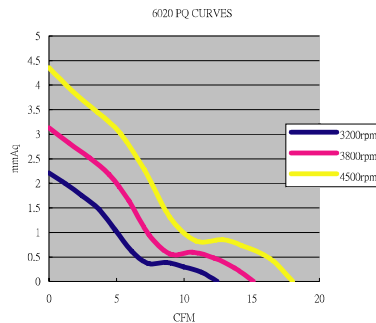

**DIMENSIONS DRAWING**

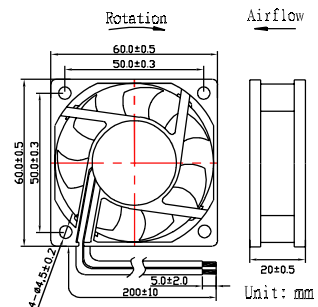

MODEL	Bearing	Rating Voltage	Rated Current	Rated Input Power	Operating Voltage Range	Speed	Air Flow	Static Pressure	Noise
PART NO.		VDC	Amp	Watts	VDC	RPM	CFM	mm-H <sub>2</sub> O	dBA
A6020H12D	Two Ball	12	0.22	2.64	6 to 13	4500	18.03	4.36	36
A6020M12D			0.18	2.16	6 to 13	3800	15.13	3.13	32
A6020L12D			0.14	1.68	6 to 13	3200	12.46	2.21	27
A6020H12C	Ball & Sleeve		0.22	2.64	6 to 13	4500	18.03	4.36	36
A6020M12C			0.18	2.16	6 to 13	3800	15.13	3.13	32
A6020L12C			0.14	1.68	6 to 13	3200	12.46	2.21	27
A6020H12S	Sleeve		0.22	2.64	6 to 13	4500	18.03	4.36	36
A6020M12S			0.18	2.16	6 to 13	3800	15.13	3.13	32
A6020L12S			0.14	1.68	6 to 13	3200	12.46	2.21	27
A6020H24D	Two Ball	24	0.11	2.64	12 to 26	4500	18.03	4.36	36
A6020M24D			0.09	2.16	12 to 26	3800	15.13	3.13	32
A6020L24D			0.07	1.68	12 to 26	3200	12.46	2.21	27
A6020H24C	Ball & Sleeve		0.11	2.64	12 to 26	4500	18.03	4.36	36
A6020M24C			0.09	2.16	12 to 26	3800	15.13	3.13	32
A6020L24C			0.07	1.68	12 to 26	3200	12.46	2.21	27
A6020H24S	Sleeve		0.11	2.64	12 to 26	4500	18.03	4.36	36
A6020M24S			0.09	2.16	12 to 26	3800	15.13	3.13	32
A6020L24S			0.07	1.68	12 to 26	3200	12.46	2.21	27

**\*MOTOR:**

4 pole brushless DC motor

**\*FRAME:**

Injection molded thermal plastic

PBT + 30% GF UL 94V-0

**\*IMPELLER:**

Injection molded thermal plastic

PBT + 15% GF UL 94V-0

**\*INSULATION:**

10M $\Omega$ /between unshackled wire

and frame at 500 VDC/m

**\*OPERATION TEMPERATURE & HUMIDITY:**

-10°C~ + 60°C, 35% ~ 85% RH

**\*STORAGE TEMPERATURE & HUMIDITY:**

-40°C~ + 70°C, 35% ~ 85% RH

**\*WIRES:**

UL1007, 26AWG, Red (+), Black (-)

**60\*60\*25 MM SERIES**

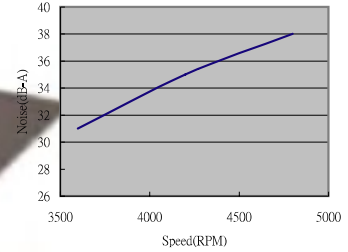

**P&Q CURVE**

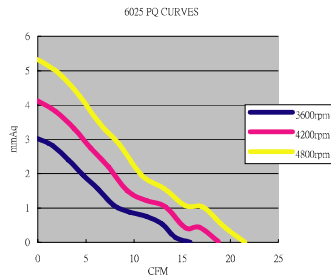

**DIMENSIONS DRAWING**

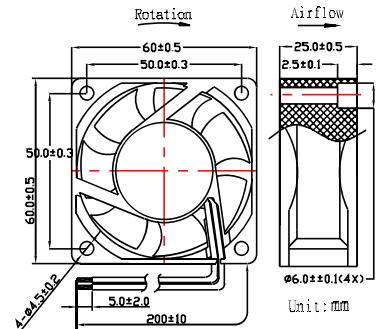

MODEL	Bearing	Rating Voltage	Rated Current	Rated Input Power	Operating Voltage Range	Speed	Air Flow	Static Pressure	Noise	
PART NO.		VDC	Amp	Watts	VDC	RPM	CFM	mm-H <sub>2</sub> O	dBA	
A6025H12D	Two Ball	12	0.22	2.64	6 to 13	4800	21.53	5.32	38	
A6025M12D			0.18	2.16	6 to 13	4200	18.76	4.12	35	
A6025L12D			0.14	1.68	6 to 13	3600	15.86	3.02	31	
A6025H12C	Ball & Sleeve		0.22	2.64	6 to 13	4800	21.53	5.32	38	
A6025M12C			0.18	2.16	6 to 13	4200	18.76	4.12	35	
A6025L12C			0.14	1.68	6 to 13	3600	15.86	3.02	31	
A6025H12S	Sleeve		0.22	2.64	6 to 13	4800	21.53	5.32	38	
A6025M12S			0.18	2.16	6 to 13	4200	18.76	4.12	35	
A6025L12S			0.14	1.68	6 to 13	3600	15.86	3.02	31	
A6025H24D	Two Ball		24	0.12	2.88	13 to 26	4800	21.53	5.32	38
A6025M24D				0.10	2.40	13 to 26	4200	18.76	4.12	35
A6025L24D				0.08	1.92	13 to 26	3600	15.86	3.02	31
A6025H24C	Ball & Sleeve	0.12		2.88	13 to 26	4800	21.53	5.32	38	
A6025M24C		0.1		2.40	13 to 26	4200	18.76	4.12	35	
A6025L24C		0.08		1.92	13 to 26	3600	15.86	3.02	31	
A6025H24S	Sleeve	0.12		2.88	13 to 26	4800	21.53	5.32	38	
A6025M24S		0.10		2.40	13 to 26	4200	18.76	4.12	35	
A6025L24S		0.08		1.92	13 to 26	3600	15.86	3.02	31	
A6025H48D	Two Ball	48		0.10	4.8	26 to 49	4800	21.53	5.32	38
A6025M48D				0.08	3.84	26 to 49	4200	18.76	4.12	35
A6025L48D				0.06	2.88	26 to 49	3600	15.86	3.02	31
A6025H48C	Ball & Sleeve		0.10	4.8	26 to 49	4800	21.53	5.32	38	
A6025M48C			0.08	3.84	26 to 49	4200	18.76	4.12	35	
A6025L48C			0.06	2.88	26 to 49	3600	15.86	3.02	31	
A6025H48S	Sleeve		0.10	4.8	26 to 49	4800	21.53	5.32	38	
A6025M48S			0.08	3.84	26 to 49	4200	18.76	4.12	35	
A6025L48S			0.06	2.88	26 to 49	3600	15.86	3.02	31	

**\*MOTOR:**

4 pole brushless DC motor

**\*FRAME:**

Injection molded thermal plastic

PBT + 30% GF UL 94V-0

**\*IMPELLER:**

Injection molded thermal plastic

PBT + 15% GF UL 94V-0

**\*INSULATION:**

10M $\Omega$ /between unshackled wire

and frame at 500 VDC/m

**\*OPERATION TEMPERATURE & HUMIDITY:**

-10°C~ + 60°C, 35% ~ 85% RH

**\*STORAGE TEMPERATURE & HUMIDITY:**

-40°C~ + 70°C, 35% ~ 85% RH

**\*WIRES:**

UL1007, 26AWG, Red (+), Black (-)

**70\*70\*10 MM SERIES**

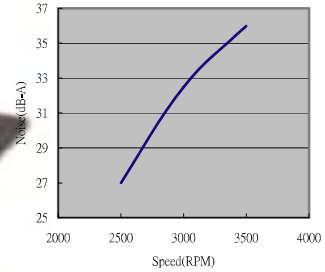

**P&Q CURVE**

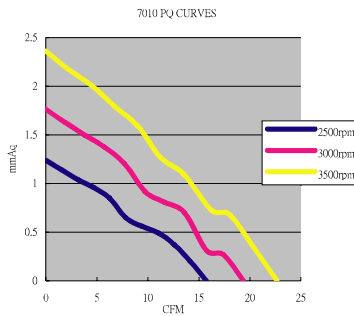

**DIMENSIONS DRAWING**

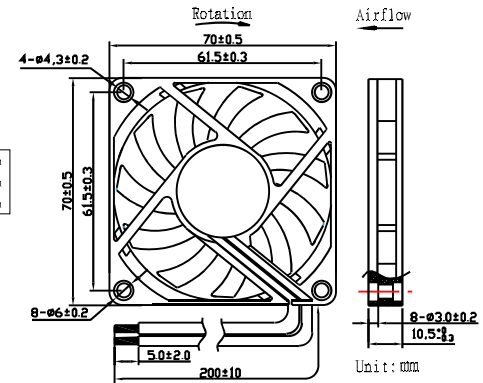

MODEL	Bearing	Rating Voltage	Rated Current	Rated Input Power	Operating Voltage Range	Speed	Air Flow	Static Pressure	Noise
PART NO.		VDC	Amp	Watts	VDC	RPM	CFM	mm-H <sub>2</sub> O	dBA
A7010H12C	Ball & Sleeve	12	0.35	4.2	6 to 13	3500	22.66	2.36	36
A7010M12C			0.22	2.64	6 to 13	3000	19.36	1.76	32.5
A7010L12C			0.18	2.16	6 to 13	2500	15.74	1.23	27
A7010H12S	Sleeve		0.35	4.2	6 to 13	3500	22.66	2.36	36
A7010M12S			0.22	2.64	6 to 13	3000	19.36	1.76	32.5
A7010L12S			0.18	2.16	6 to 13	2500	15.74	1.23	27

**\*MOTOR:**

4 pole brushless DC motor

**\*FRAME:**

Injection molded thermal plastic

PBT + 30% GF UL 94V-0

**\*IMPELLER:**

Injection molded thermal plastic

PBT + 15% GF UL 94V-0

**\*INSULATION:**

10MΩ/between unshackled wire

and frame at 500 VDC/m

**\*OPERATION TEMPERATURE & HUMIDITY:**

-10°C~ + 60°C, 35% ~ 85% RH

**\*STORAGE TEMPERATURE & HUMIDITY:**

-40°C~ + 70°C, 35% ~ 85% RH

**\*WIRES:**

UL1007, 26AWG, Red (+), Black (-)

**70\*70\*15 MM SERIES**

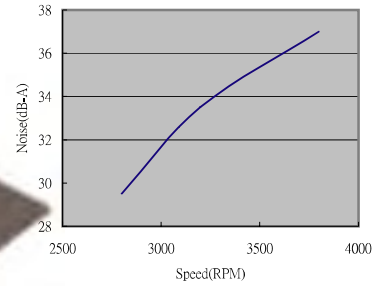

**P&Q CURVE**

**DIMENSIONS DRAWING**

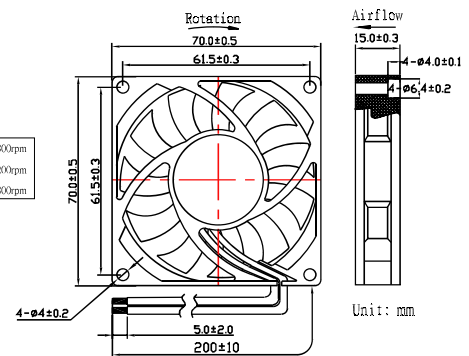
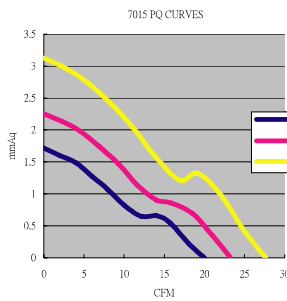

MODEL	Bearing	Rating Voltage	Rated Current	Rated Input Power	Operating Voltage Range	Speed	Air Flow	Static Pressure	Noise
PART NO.		VDC	Amp	Watts	VDC	RPM	CFM	mm-H <sub>2</sub> O	dB A
A7015H12D	Two Ball	12	0.26	3.12	6 to 13	3800	27.66	3.12	37
A7015M12D			0.22	2.64	6 to 13	3200	23.30	2.25	33.5
A7015L12D			0.18	2.16	6 to 13	2800	20.17	1.72	29.5
A7015H12C	Ball & Sleeve		0.26	3.12	6 to 13	3800	27.66	3.12	37
A7015M12C			0.22	2.64	6 to 13	3200	23.30	2.25	33.5
A7015L12C			0.18	2.16	6 to 13	2800	20.17	1.72	29.5
A7015H12S	Sleeve		0.26	3.12	6 to 13	3800	27.66	3.12	37
A7015M12S			0.22	2.64	6 to 13	3200	23.30	2.25	33.5
A7015L12S			0.18	2.16	6 to 13	2800	20.17	1.72	29.5



## 75\*75\*30 MM SERIES

**\*MOTOR:**

4 pole brushless DC motor

**\*FRAME:**

Injection molded thermal plastic

PBT + 30% GF UL 94V-0

**\*IMPELLER:**

Injection molded thermal plastic

PBT + 15% GF UL 94V-0

**\*INSULATION:**

10MΩ/between unshackled wire  
and frame at 500 VDC/m

**\*OPERATION TEMPERATURE & HUMIDITY:**

-10°C ~ +60°C, 35% ~ 85% RH

**\*STORAGE TEMPERATURE & HUMIDITY:**

-40°C ~ +70°C, 35% ~ 85% RH

**\*WIRES:**

UL1007, 26AWG, Red (+), Black (-)

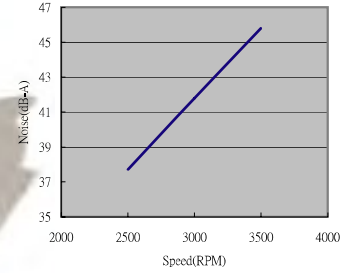

**P&Q CURVE**

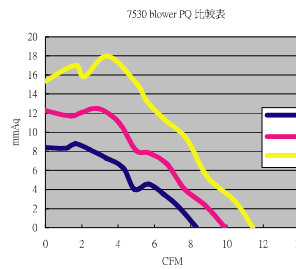

**DIMENSIONS DRAWING**

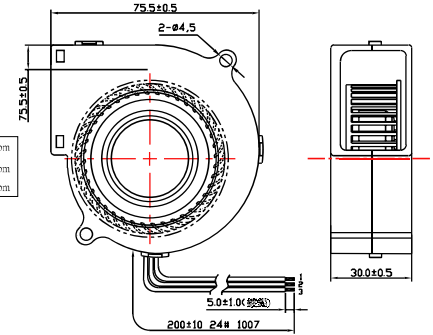

MODEL	Bearing	Rating Voltage	Rated Current	Rated Input Power	Operating Voltage Range	Speed	Air Flow	Static Pressure	Noise
PART NO.		VDC	Amp	Watts	VDC	RPM	CFM	mm-H <sub>2</sub> O	dBA
B7530H12D	Two Ball	12	0.45	5.4	6 to 13	3500	11.43	15.32	45.8
B7530M12D			0.40	4.8	6 to 13	3000	9.91	12.28	41.8
B7530L12D			0.35	4.2	6 to 13	2500	8.33	8.40	37.7
B7530H12C	Ball & Sleeve		0.45	5.4	6 to 13	3500	11.43	15.32	45.8
B7530M12C			0.40	4.8	6 to 13	3000	9.91	12.28	41.8
B7530S12C			0.35	4.2	6 to 13	2500	8.33	8.40	37.7
B7530H12S	Sleeve		0.45	5.4	6 to 13	3500	11.43	15.32	45.8
B7530M12S			0.40	4.8	6 to 13	3000	9.91	12.28	41.8
B7530L12S			0.35	4.2	6 to 13	2500	8.33	8.40	37.7

**\*MOTOR:**

4 pole brushless DC motor

**\*FRAME:**

Injection molded thermal plastic

PBT + 30% GF UL 94V-0

**\*IMPELLER:**

Injection molded thermal plastic

PBT + 15% GF UL 94V-0

**\*INSULATION:**

10M $\Omega$ /between unshackled wire  
and frame at 500 VDC/m

**\*OPERATION TEMPERATURE & HUMIDITY:**

-10°C ~ + 60°C, 35% ~ 85% RH

**\*STORAGE TEMPERATURE & HUMIDITY:**

-40°C ~ + 70°C, 35% ~ 85% RH

**\*WIRES:**

UL1007, 26AWG, Red (+), Black (-)

**80\*80\*10 MM SERIES**

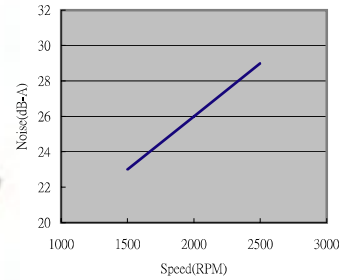

**P&Q CURVE**

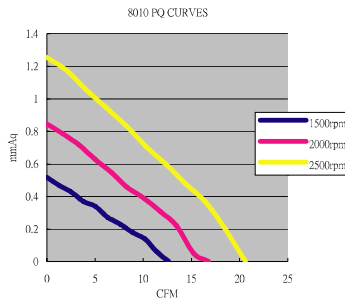

**DIMENSIONS DRAWING**

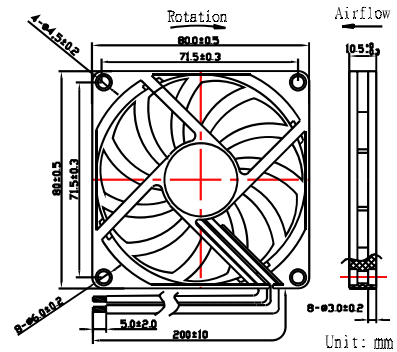

MODEL	Bearing	Rating Voltage	Rated Current	Rated Input Power	Operating Voltage Range	Speed	Air Flow	Static Pressure	Noise
PART NO.		VDC	Amp	Watts	VDC	RPM	CFM	mm-H <sub>2</sub> O	dB(A)
A8010H12C	Ball & Sleeve	12	0.35	4.20	6 to 13	2500	20.63	1.25	29
A8010M12C			0.25	3.00	6 to 13	2000	16.8	0.85	26
A8010L12C			0.15	1.80	6 to 13	1500	12.66	0.52	23
A8010H12S	Sleeve		0.35	4.20	6 to 13	2500	20.63	1.25	29
A8010M12S			0.25	3.00	6 to 13	2000	16.8	0.85	26
A8010L12S			0.15	1.80	6 to 13	1500	12.66	0.52	23

### 80\*80\*15 MM SERIES

**\*MOTOR:**

4 pole brushless DC motor

**\*FRAME:**

Injection molded thermal plastic

PBT + 30% GF UL 94V-0

**\*IMPELLER:**

Injection molded thermal plastic

PBT + 15% GF UL 94V-0

**\*INSULATION:**

10MΩ/between unshackled wire

and frame at 500 VDC/m

**\*OPERATION TEMPERATURE & HUMIDITY:**

-10°C~ + 60°C, 35% ~ 85% RH

**\*STORAGE TEMPERATURE & HUMIDITY:**

-40°C~ + 70°C, 35% ~ 85% RH

**\*WIRES:**

UL1007, 26AWG, Red (+), Black (-)

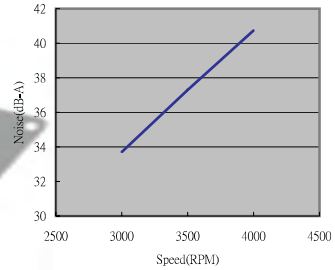

**P&Q CURVE**

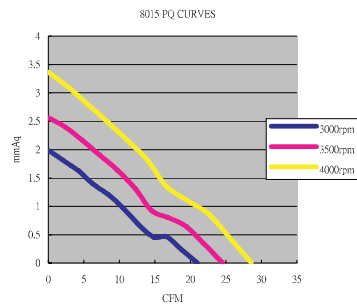

**DIMENSIONS DRAWING**

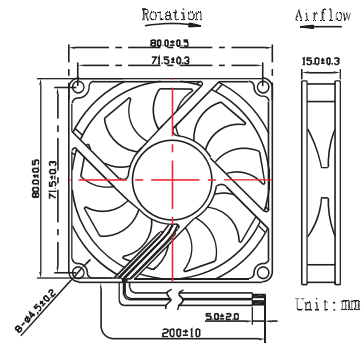

MODEL	Bearing	Rating Voltage	Rated Current	Rated Input Power	Operating Voltage Range	Speed	Air Flow	Static Pressure	Noise
PART NO.		VDC	Amp	Watts	VDC	RPM	CFM	mm-H <sub>2</sub> O	dBA
A8015H12D	Two Ball	12	0.24	2.88	6 to 13	4000	28.59	3.36	40.75
A8015M12D			0.2	2.4	6 to 13	3500	24.55	2.56	37.3
A8015L12D			0.16	1.92	6 to 13	3000	20.98	1.99	33.7
A8015H12C	Ball & Sleeve		0.24	2.88	6 to 13	4000	28.59	3.36	40.75
A8015M12C			0.2	2.4	6 to 13	3500	24.55	2.56	37.3
A8015L12C			0.16	1.92	6 to 13	3000	20.98	1.99	33.7
A8015H12S	Sleeve		0.24	2.88	6 to 13	4000	28.59	3.36	40.75
A8015M12S			0.2	2.4	6 to 13	3500	24.55	2.56	37.3
A8015L12S			0.16	1.92	6 to 13	3000	20.98	1.99	33.7

### 80\*80\*20 MM SERIES

**\*MOTOR:**

4 pole brushless DC motor

**\*FRAME:**

Injection molded thermal plastic

PBT + 30% GF UL 94V-0

**\*IMPELLER:**

Injection molded thermal plastic

PBT + 15% GF UL 94V-0

**\*INSULATION:**

10MΩ/between unshackled wire

and frame at 500 VDC/m

**\*OPERATION TEMPERATURE & HUMIDITY:**

-10°C~ + 60°C, 35% ~ 85% RH

**\*STORAGE TEMPERATURE & HUMIDITY:**

-40°C~ + 70°C, 35% ~ 85% RH

**\*WIRES:**

UL1007, 26AWG, Red (+), Black (-)

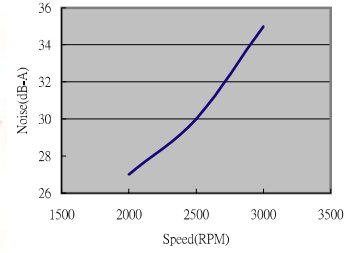

**P&Q CURVE**

8020 PQ CURVES

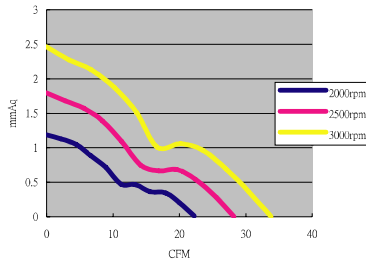

**DIMENSIONS DRAWING**

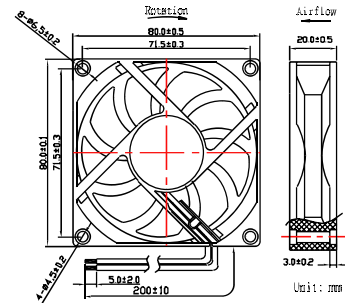

MODEL	Bearing	Rating Voltage	Rated Current	Rated Input Power	Operating Voltage Range	Speed	Air Flow	Static Pressure	Noise
PART NO.		VDC	Amp	Watts	VDC	RPM	CFM	mm-H <sub>2</sub> O	dB(A)
A8020H12D	Two Ball	12	0.20	2.4	6 to 13	3000	33.83	2.46	35
A8020M12D			0.16	1.92	6 to 13	2500	28.23	1.79	30
A8020L12D			0.12	1.44	6 to 13	2000	22.28	1.19	27
A8020H12C	Ball & Sleeve		0.20	2.4	6 to 13	3000	33.83	2.46	35
A8020M12C			0.16	1.92	6 to 13	2500	28.23	1.79	30
A8020L12C			0.12	1.44	6 to 13	2000	22.28	1.19	27
A8020H12S	Sleeve		0.20	2.4	6 to 13	3000	33.83	2.46	35
A8020M12S			0.16	1.92	6 to 13	2500	28.23	1.79	30
A8020L12S			0.12	1.44	6 to 13	2000	22.28	1.19	27
A8020H24D	Two Ball	24	0.12	2.88	12 to 26	3000	33.83	2.46	35
A8020M24D			0.1	2.40	12 to 26	2500	28.23	1.79	30
A8020L24D			0.08	1.92	12 to 26	2000	22.28	1.19	27
A8020H24C	Ball & Sleeve		0.12	2.88	12 to 26	3000	33.83	2.46	35
A8020M24C			0.1	2.40	12 to 26	2500	28.23	1.79	30
A8020L24C			0.08	1.9	12 to 26	2000	22.28	1.19	27
A8020H24S	Sleeve		0.12	2.88	12 to 26	3000	33.83	2.46	35
A8020M24S			0.1	2.40	12 to 26	2500	28.23	1.79	30
A8020L24S			0.08	1.92	12 to 26	2000	22.28	1.19	27

### 80\*80\*25 MM SERIES

**\*MOTOR:**

4 pole brushless DC motor

**\*FRAME:**

Injection molded thermal plastic  
PBT + 30% GF UL 94V-0

**\*IMPELLER:**

Injection molded thermal plastic  
PBT+15%GF UL 94V-0

**\*INSULATION:**

10M $\Omega$ /between unshackled wire  
and frame at 500 VDC/m

**\*OPERATION TEMPERATURE & HUMIDITY:**

-10°C ~ +60°C, 35% ~ 85% RH

**\*STORAGE TEMPERATURE & HUMIDITY:**

-40°C ~ +70°C, 35% ~ 85% RH

**\*WIRES:**

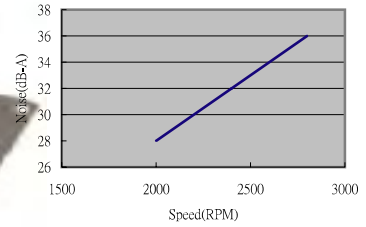

**P&Q CURVE**

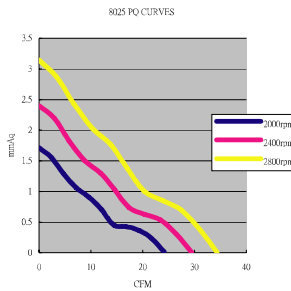

**DIMENSIONS DRAWING**

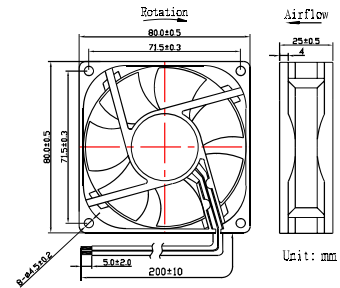

MODEL	Bearing	Rating Voltage	Rated Current	Rated Input Power	Operating Voltage Range	Speed	Air Flow	Static Pressure	Noise	
PART NO.		VDC	Amp	Watts	VDC	RPM	CFM	mm-H <sub>2</sub> O	dBA	
A8025H12D	Two Ball	12	0.16	1.92	6 to 13	2800	34.38	3.14	36	
A8025M12D			0.12	1.44	6 to 13	2400	29.49	2.40	32	
A8025L12D			0.1	1.2	6 to 13	2000	24.22	1.71	28	
A8025H12C	Ball & Sleeve		0.16	1.92	6 to 13	2800	34.38	3.14	36	
A8025M12C			0.12	1.44	6 to 13	2400	29.49	2.40	32	
A8025L12C			0.1	1.2	6 to 13	2000	24.22	1.71	28	
A8025H12S	Sleeve		0.16	1.92	6 to 13	2800	34.38	3.14	36	
A8025M12S			0.12	1.44	6 to 13	2400	29.49	2.40	32	
A8025L12S			0.1	1.2	6 to 13	2000	24.22	1.71	28	
A8025H12D	Two Ball	24	0.12	2.88	12 to 26	2800	34.38	3.14	36	
A8025M24D			0.09	2.16	12 to 26	2400	29.49	2.40	32	
A8025L24D			0.07	1.68	12 to 26	2000	24.22	1.71	28	
A8025H24C	Ball & Sleeve		0.12	2.88	12 to 26	2800	34.38	3.14	36	
A8025M24C			0.09	2.16	12 to 26	2400	29.49	2.40	32	
A8025L24C			0.07	1.68	12 to 26	2000	24.22	1.71	28	
A8025H24S	Sleeve		0.12	2.88	12 to 26	2800	34.38	3.14	36	
A8025M24S			0.09	2.16	12 to 26	2400	29.49	2.40	32	
A8025L24S			0.07	1.68	12 to 26	2000	24.22	1.71	28	
A8025H48D	Two Ball		48	0.10	4.8	26 to 49	2800	34.38	3.14	36
A8025M48D				0.08	3.84	26 to 49	2400	29.49	2.40	32
A8025L48D				0.05	2.4	26 to 49	2000	24.22	1.71	28
A8025H48C	Ball & Sleeve	0.10		4.8	26 to 49	2800	34.38	3.14	36	
A8025M48C		0.08		3.84	26 to 49	2400	29.49	2.40	32	
A8025L48C		0.05		2.4	26 to 49	2000	24.22	1.71	28	
A8025H48S	Sleeve	0.10		4.8	26 to 49	2800	34.38	3.14	36	
A8025M48S		0.08		3.84	26 to 49	2400	29.49	2.40	32	
A8025L48S		0.05		2.4	26 to 49	2000	24.22	1.71	28	

**\*MOTOR:**

4 pole brushless DC motor

**\*FRAME:**

Injection molded thermal plastic

PBT+30%GF UL 94V-0

**\*IMPELLER:**

Injection molded thermal plastic

PBT + 15% GF UL 94V-0

**\*INSULATION:**

10MΩ/between unshackled wire

and frame at 500 VDC/m

**\*OPERATION TEMPERATURE & HUMIDITY:**

-10°C~ + 60°C, 35% ~ 85% RH

**\*STORAGE TEMPERATURE & HUMIDITY:**

-40°C~ + 70°C, 35% ~ 85% RH

**\*WIRES:**

UL1007, 26AWG, Red (+), Black (-)

**92\*92\*25 MM SERIES**

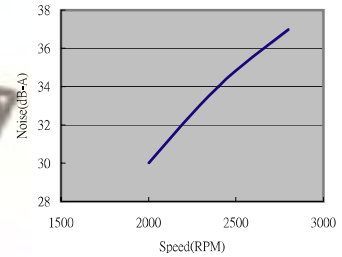

**P&Q CURVE**

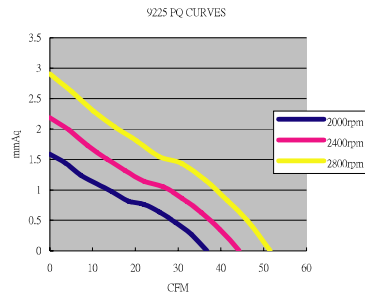

**DIMENSIONS DRAWING**

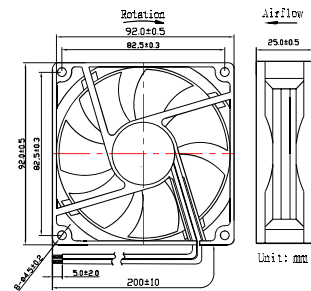

MODEL	Bearing	Rating Voltage	Rated Current	Rated Input Power	Operating Voltage Range	Speed	Air Flow	Static Pressure	Noise	
PART NO.		VDC	Amp	Watts	VDC	RPM	CFM	mm-H <sub>2</sub> O	dBA	
A9225H12D	Two Ball	12	0.34	4.08	6 to 13	2800	51.54	2.91	37	
A9225M12D			0.26	3.12	6 to 13	2400	44.34	2.18	34	
A9225L12D	0.2		2.4	6 to 13	2000	36.78	1.59	30		
A9225H12C	Ball & Sleeve		0.34	4.08	6 to 13	2800	51.54	2.91	37	
A9225M12C			0.26	3.12	6 to 13	2400	44.34	2.18	34	
A9225L12C	0.2		2.4	6 to 13	2000	36.78	1.59	30		
A9225H12S	Sleeve		0.34	4.08	6 to 13	2800	51.54	2.91	37	
A9225M12S			0.26	3.12	6 to 13	2400	44.34	2.18	34	
A9225L12S	0.2		2.4	6 to 13	2000	36.78	1.59	30		
A9225H24D	Two Ball		24	0.17	4.08	12 to 26	2800	51.54	2.91	37
A9225M24D				0.13	3.12	12 to 26	2400	44.34	2.18	34
A9225L24D	0.1			2.4	12 to 26	2000	36.78	1.59	30	
A9225H24C	Ball & Sleeve	0.17		4.08	12 to 26	2800	51.54	2.91	37	
A9225M24C		0.13		3.12	12 to 26	2400	44.34	2.18	34	
A9225L24C	0.1	2.4		12 to 26	2000	36.78	1.59	30		
A9225H24S	Sleeve	0.17		4.08	12 to 26	2800	51.54	2.91	37	
A9225M24S		0.13		3.12	12 to 26	2400	44.34	2.18	34	
A9225L24S	0.1	2.4		12 to 26	2000	36.78	1.59	30		
A9225H48D	Two Ball	48		0.12	5.76	26 to 49	2800	51.54	2.91	37
A9225M48D				0.10	4.80	26 to 49	2400	44.34	2.18	34
A9225L48D	0.08			3.84	26 to 49	2000	36.78	1.59	30	
A9225H48C	Ball & Sleeve		0.12	5.76	26 to 49	2800	51.54	2.91	37	
A9225M48C			0.10	4.80	26 to 49	2400	44.34	2.18	34	
A9225L48C	0.08		3.84	26 to 49	2000	36.78	1.59	30		
A9225H48S	Sleeve		0.12	5.76	26 to 49	2800	51.54	2.91	37	
A9225M48S			0.10	4.80	26 to 49	2400	44.34	2.18	34	
A9225L48S	0.08		3.84	26 to 49	2000	36.78	1.59	30		

**\*MOTOR:**

4 pole brushless DC motor

**\*FRAME:**

Injection molded thermal plastic

PBT + 30% GF UL 94V-0

**\*IMPELLER:**

Injection molded thermal plastic

PBT + 15% GF UL 94V-0

**\*INSULATION:**

10M $\Omega$ /between unshackled wire and frame at 500 VDC/m

**\*OPERATION TEMPERATURE & HUMIDITY:**

-10°C~ + 60°C, 35% ~ 85% RH

**\*STORAGE TEMPERATURE & HUMIDITY:**

-40°C~ + 70°C, 35% ~ 85% RH

**\*WIRES:**

UL1007, 26AWG, Red (+), Black (-)

**92\*92\*38 MM SERIES**

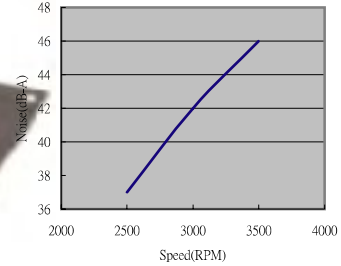

**P&Q CURVE**

9238 PQ CURVE

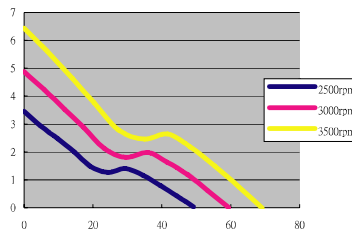

**DIMENSIONS DRAWING**

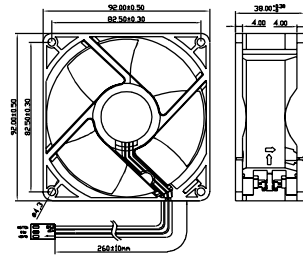

MODEL	Bearing	Rating Voltage	Rated Current	Rated Input Power	Operating Voltage Range	Speed	Air Flow	Static Pressure	Noise	
PART NO.		VDC	Amp	Watts	VDC	RPM	CFM	mm-H <sub>2</sub> O	dB(A)	
A9238H12D	Two Ball	12	0.60	7.2	6 to 13	3500	69.27	6.44	46	
A9238M12D			0.50	6.0	6 to 13	3000	59.42	4.87	42	
A9238L12D			0.40	4.8	6 to 13	2500	49.31	3.46	37	
A9238H24D		24	24	0.36	8.64	12 to 26	3500	69.27	6.44	46
A9238M24D				0.28	6.72	12 to 26	3000	59.42	4.87	42
A9238L24D				0.20	4.8	12 to 26	2500	49.31	3.46	37
A9238H48D		48	48	0.25	12	26 to 49	3500	69.27	6.44	46
A9238M48D				0.20	9.6	26 to 49	3000	59.42	4.87	42
A9238L48D				0.15	7.2	26 to 49	2500	49.31	3.46	37





# FAN CATALOG REVIEW

## ENGINEERING

### We design and test fans using the following:

- Dedicated fan engineering and technical staff
- Proprietary fan design software for design verification of flow, pressure and noise
- CAD design of all components, including PCB, motor, housing and impeller
- Prototyping
- Wind tunnels for testing flow and pressure performance
- Anechoic chamber for noise levels
- Burn-In ovens for long term life testing

## PRODUCTION

### Our in-house production processes include:

- SMT assembly lines for the printed circuit board
- Motor winding
- Motor assembly
- Impeller balancing
- Acoustic tests
- Custom lead and connector assembly

## QUALITY

Vette's global team is committed to providing reliable, quality fans to its customers with the best price/performance available. Vette is a certified manufacturer for heat sinks and fans.

- UL
- TUV
- CE
- ISO-9000
- Green Partner

## RoHS COMPLIANCE

- All materials and processes used in the fabrication of our fans are compliant with EU Directive 2002/95/EC Section 4.1 The European Parliament has issued this Restriction of Hazardous Substances (RoHS) Directive requiring that new electrical and electronic products put on the market after July 1, 2006 do not contain lead, cadmium, mercury, hexavalent chrome, polybrominated biphenyls (PBB) or polybrominated diphenyl ethers.
- Vette no longer intentionally adds any of these 6 restricted substances to its products, and as a result most Vette products do not contain the banned substances at levels above approximately 50 parts per million, or 0.005 percent.
- Vette's environmental goal is to provide environmentally responsible products.